

# auta

## DIGITAL



REF. 754205

ES MONITOR COMPACT, INTERCOM

EN COMPACT MONITOR, INTERCOM

## Descripción Description

**Monitor digital COLOR.** Permite la intercomunicación de hasta 6 terminales y la comunicación con placas de calle. Incorpora una pantalla LCD COLOR 4", audio HD, salidas auxiliares multi-función, selección de melodías, funciones especiales.

**COLOUR digital monitor.** Allow intercom up to 6 terminals and the communication with external panels. It incorporates a LCD COLOUR 4",HD audio, auxiliary multi-function outputs, selection of melodies, special functions.

## Características Features

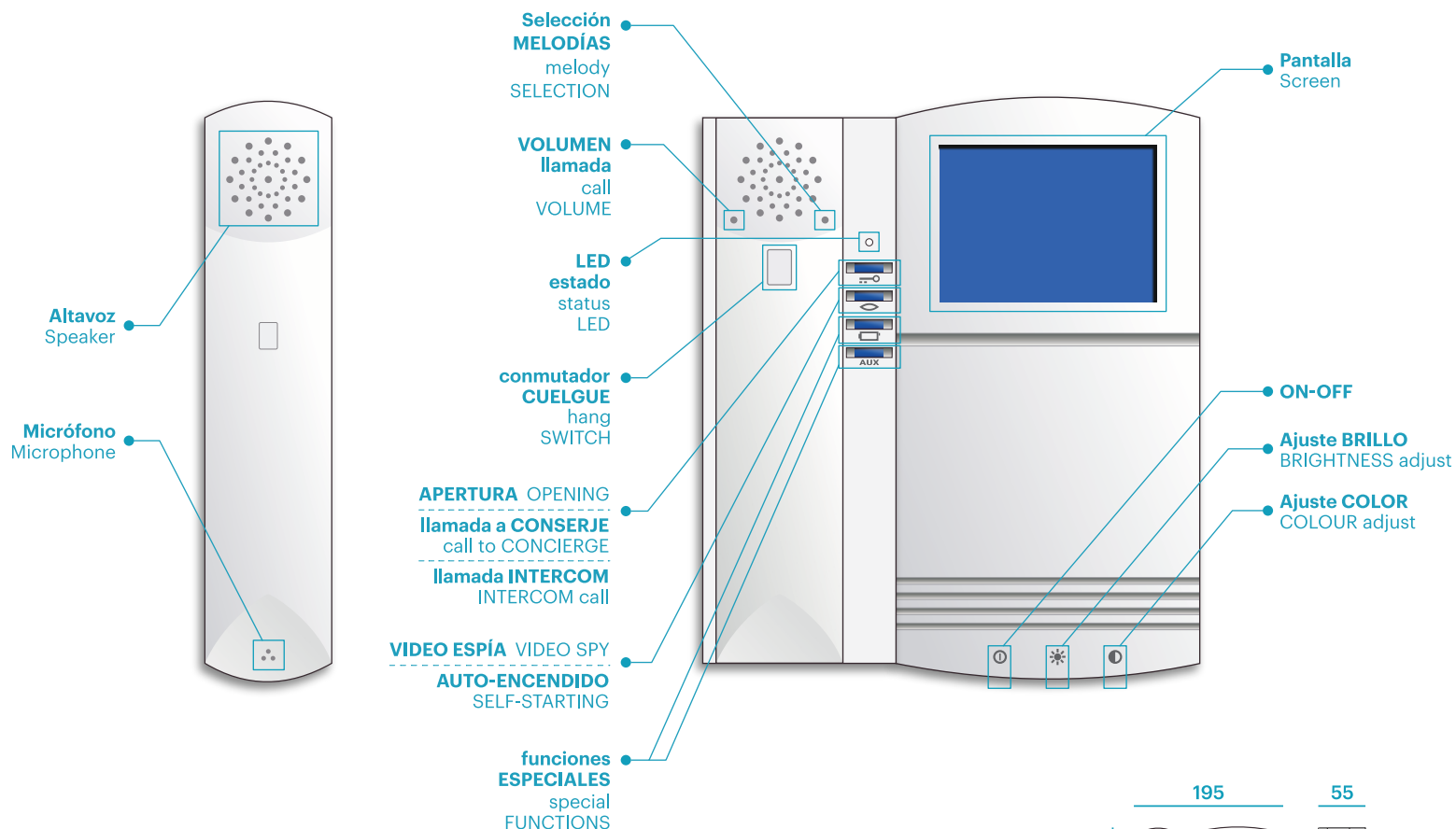

## Montaje Mounting

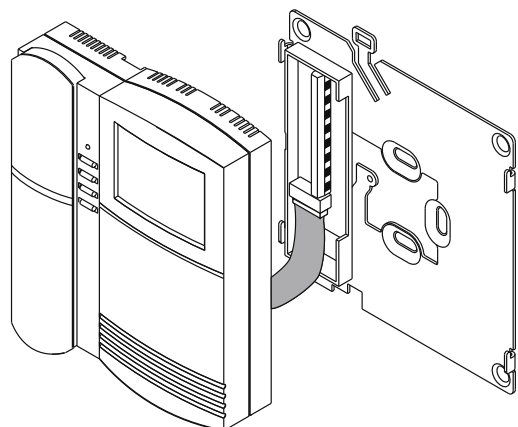

**Superficie**  
**(módulo de conexión, NO INCLUIDO)**  
Surface  
(connection bracket, NOT INCLUDED)

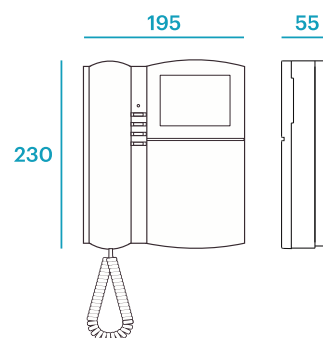

**Escritorio**  
**(adaptador 730482, NO INCLUIDO)**  
Desk  
(adapter 730482, NOT INCLUDED)

## Instalación Installation

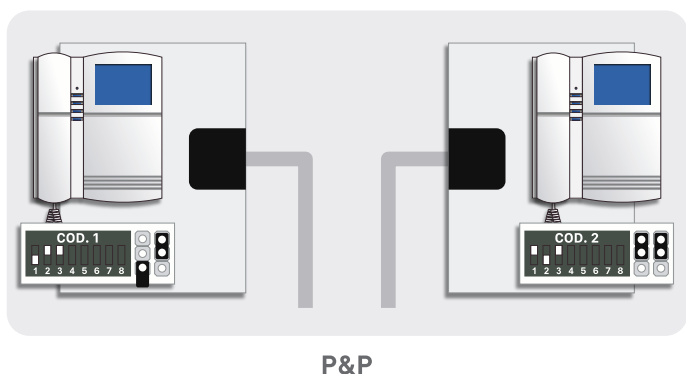
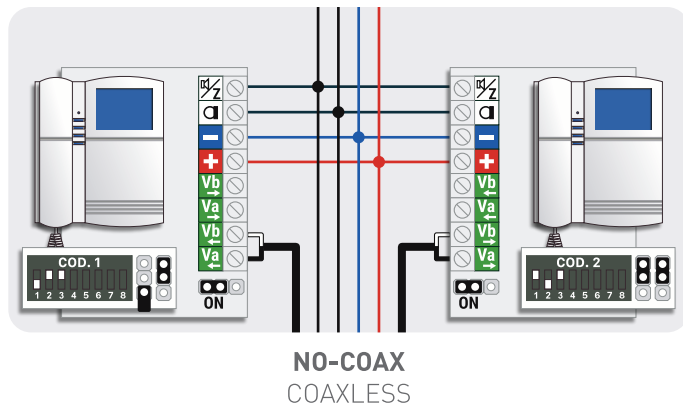
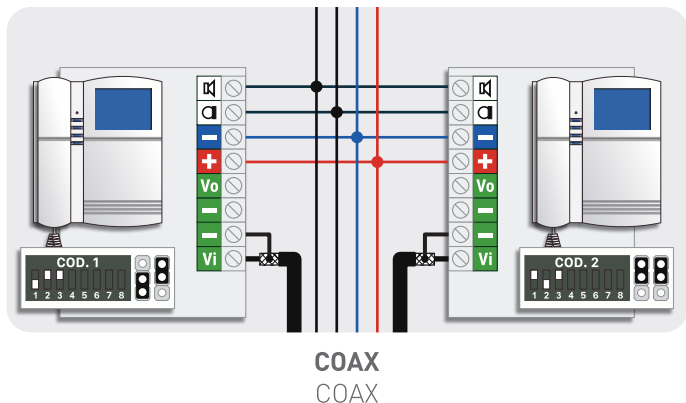

Manual de instalación INTERCOM  
Installation manual INTERCOM

## Configuración Configuration

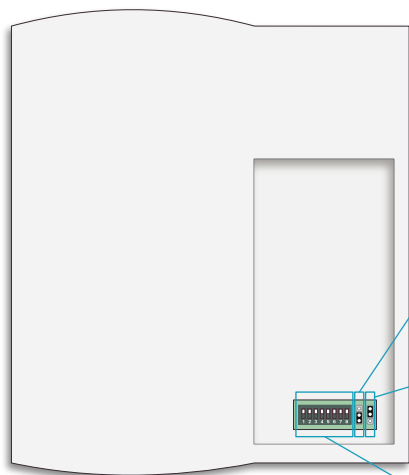

• **Selector PRINCIPAL\_SECUNDARIO**  
MAIN\_SECONDARY selector

Principal (75Ω → COAX)  
Main (75Ω → COAX)

Principal (0Ω → NO-COAX\_P&P)  
Main (0Ω → COAXLESS\_P&P)

Secundario (0Ω)  
Secondary (0Ω)

• **Selector AUTO-ENCENDIDO**  
SELF-STARTING selector

Desactivado  
Disabled

Activado  
Activated

• **Código de llamada INTERCOM (binario)** INTERCOM call code (binary)



> **Ajustes especiales** Special settings



\*



**Solo recepción de llamadas**  
Only calls reception



**Solo llamadas intercom**  
Only intercom calls



**Modo prioritario SI**  
Priority mode ON

\* Al activar este modo el teléfono responde a llamadas de placa que coincidan con su mismo código INTERCOM. Por ejemplo, si el teléfono tiene su código intercom como 2, al activar este modo, también responderá al pulsador de placa 2.



When this mode is activated the telephone will answer call from panel which match with its own INTERCOM code. For example, if the telephone has code 2 as intercom code, when that mode is activated, also will answer to the push-button 2 of the panel.

# Funcionamiento

ES

## llamada y conversación

Cuando se recibe una llamada desde placa de calle el monitor comienza a sonar durante un tiempo máximo de 30 segundos. De forma estándar efectúa 4 timbrados con intervalos de 4 segundos entre cada uno de ellos.

Durante el periodo de llamada la imagen aparece en la pantalla, el usuario podrá abrir directamente, presionando el pulsador  o descolgar el auricular para establecer una conversación. La conversación tiene un máximo de 90 segundos. Si se desea continuar con la conversación se deberá presionar el pulsador .

## llamada INTERCOM

Estando el teléfono en reposo se presiona el pulsador  tantas veces como el número de monitor interior al que se desea llamar. El monitor realiza un tono de confirmación con cada pulsación y el LED de estado parpadea tantas veces como el número de monitor al que se efectuará la llamada. Seguidamente se descuelga el auricular, el sistema activará comunicación automática con el monitor seleccionado.

## función llamada general

Estando el teléfono en reposo se presiona el pulsador  durante 3 segundos, el LED comenzará a emitir destellos rápidos. Al descolgar el auricular se efectuará una llamada a todos los elementos presentes en la instalación.

## auto-encendido

Presionando el pulsador  el usuario podrá establecer comunicación con la PLACA DE CALLE / CÁMARA CCTV que desee en el caso de existir más de una en la instalación.

Con cada pulsación el sistema conmutará automáticamente al siguiente dispositivo, mostrando imagen y permitiendo la apertura de este presionando el pulsador .

## llamada a conserje

Si estando el monitor en reposo se descuelga el auricular y se presiona el pulsador  se efectuará una llamada a central de conserjería. Si el sistema no cuenta con ninguna central instalada el monitor emitirá un aviso de error.

## ajuste del volumen de llamada

Para ajustar el volumen de la llamada se ha de introducir un clip o similar por el orificio indicado y presionar levemente. El monitor cuenta con dos niveles de volumen (MEDIO y ALTO)



## selección de melodías

Para seleccionar una melodía de llamada se ha de descolgar el auricular y presionar con el dedo el conmutador de cuelgue. Con él presionado se ha de introducir un clip o similar en el orificio indicado presionando suavemente.

Cada pulsación selecciona una melodía diferente entre 7 disponibles para la placa con ID impar. La placa con ID par tendrá, de forma automática, la melodía siguiente a la seleccionada



## función ding dong

El monitor permite prescindir del timbre interior de la vivienda, integrando así las dos llamadas (placa exterior y vivienda) en un solo dispositivo. Se diferenciarán automáticamente dichas llamadas con melodías y destellos diferentes. Para disponer de esta función tan solo se ha de conectar el pulsador de la vivienda interior al monitor.

## función vigilancia cctv

El monitor permite el control de placas y cámaras CCTV automáticamente. Cada pulsación en el pulsador  activará un dispositivo diferente. Para ello se ha de instalar cada cámara CCTV junto a un interface Auta digital.

## funciones externas

El monitor dispone de 2 pulsadores independientes que permiten realizar maniobras auxiliares, como el accionamiento de puertas de garaje, encendido de luces, riego, etc...

Para ello se usará un relé auxiliar Auta conectado al circuito de maniobra que se desee controlar.



## Modo prioritario

Al activar este modo el teléfono es capaz de finalizar cualquier conversación que en ese momento este teniendo lugar en el sistema. Liberando así la línea de comunicación.

## Functioning

### calling and conversation

When a call is received from the entrance panel, the monitor starts ringing for a maximum of 30 seconds. As standard, it performs 4 rings with intervals of 4 seconds between each of them.

During the call period the image appears on the screen, the user can open directly, pressing the button , or pick up the handset to establish conversation. The conversation has a maximum of 90 seconds. If you want to continue with the conversation, press the button .

### INTERCOM calling

When the phone is on standby, press the button  as many times as the internal monitor number you wish to call. The monitor makes a confirmation tone with each press and the status LED flashes as many times as the monitor number to which the call will be made. After the handset is picked up, the system will activate automatic communication with the selected monitor.

### broadcast calling function

With the phone in standby press the button  during 3 seconds, the LED starts blinking fast. When you pick up the handset it will make a calling to all devices installed at system.

### self-starting

By pressing the button  the user can establish communication with the PANEL / CCTV CAMERA that he wishes in the case of more than one is present in the installation.

With each press the system will automatically switch to the next device, showing the image and allowing the opening of it by pressing the button .

### calling to concierge

If the monitor is in standby, handset is picked up and the button  is pressed, a call will be made to the concierge unit. If the system does not have a concierge unit installed, the monitor will emit an error beep.

### adjust of the calling volume

To adjust the volume of the call, insert a clip or similar through the indicated hole and press with it lightly.

The monitor has two volume levels (MEDIUM and HIGH)



### melody selection

To select a ringtone, pick up the handset and press the hook switch with your finger. With it pressed, insert a clip or similar into the indicated hole, pressing gently.

Each press selects a different melody among 7 available for the plate with odd ID. The panel with even ID will automatically have the melody following the one selected

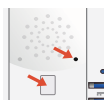

### ding dong function

The monitor allows to replace the interior bell of the house, this integrates the two calls (outside panel and house bell) in a single device. These calls will be differentiated with different melodies and flashes automatically. In order to have this function, you only have to connect the button of the house bell to the monitor.

### cctv surveillance function

The monitor allows the control of panels and CCTV cameras automatically. Each press on the button  activates a different device. To do this, each CCTV camera must be installed with an Auta digital interface.

### external functions

The monitor has 2 independent push-buttons that allow auxiliary functions, such as garage doors, lights, irrigation, etc ... To do this, an Auta auxiliary relay must be connected to the control circuit we want to control.

### Priority mode

By activating this mode the phone is able to end any conversation that is currently taking place in the system. Leaving free the communication line.





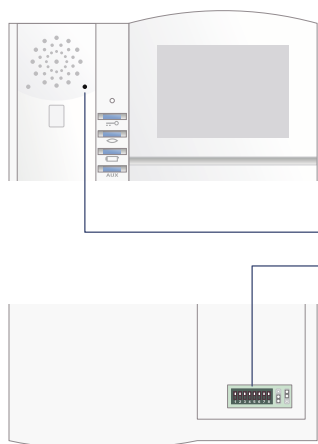









# Funciones especiales Special functions

## Programación de funciones especiales Programming of special functions



1°	Apagar el monitor	Turn OFF the monitor
2°	Anotar configuración del monitor	Write down monitor settings
3°	Realizar un puente como indica el dibujo	Do a bridge as picture shows
4°	Descolgar el auricular	Pick up the handset
5°	Configurar el código de función (tabla)	Set the desired function code (template)
6°	Encender el monitor	Turn ON the monitor
7°	Validar el código presionando el pulsador para selección de melodías.	Validate the code by pressing the melody selection push-button
8°	Apagar el monitor	Turn OFF the monitor
9°	Deshacer el puente realizado en el paso 3	Remove the bridge done in the step 3
10°	Restablecer configuración del monitor anotada en el paso 2	Restore the monitor configuration written in the step 2
11°	Encender el monitor	Turn ON the monitor

## Tabla de funciones especiales Special functions table

FUNCIÓN FUNCTION		BINARIO BINARY
1, 2, 3, 4	<b>Nº de tonos de llamada</b> Nº of calling tones	 1 tono 1 tone  2 tonos 2 tones  3 tonos 3 tones  4 tonos 4 tones
5	<b>Modo silencio, la salida  se activa tantas veces como el Nº de tonos</b> Silent mode, the output  is activated as many times as the Nº of tones	
6	<b>La salida  se activa durante 30 segundos al recibir una llamada</b> The output  is activated during 30 seconds when a call is received	
7	<b>La salida  se activará en modo PULSO (1 segundo)</b> The output  be activated in PULSE mode (1 second)	
8	<b>La salida  se activará en modo ON-OFF (cada pulsación cambia estado)</b> The output  be activated in ON-OFF mode (every push it changes state)	