

QUICK

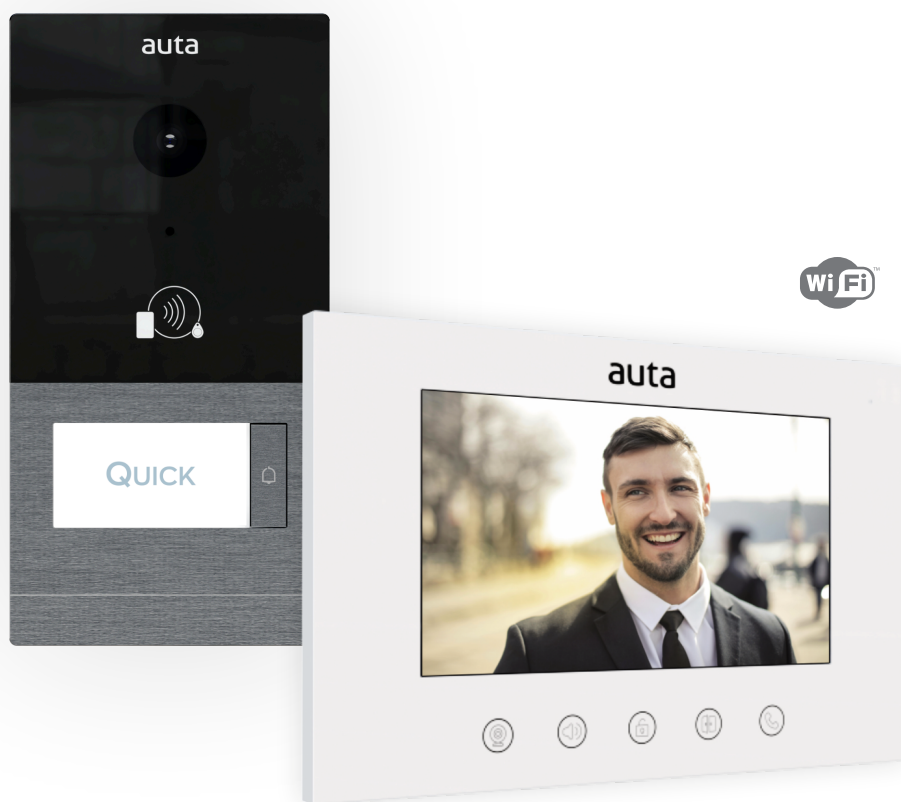

2H



REF: 745402

ES KIT QUICK 2H Wi-Fi

EN QUICK 2W Wi-Fi KIT

auta

Bringing people together

Descripción monitor Monitor description

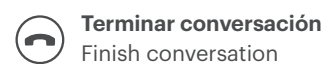
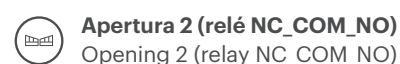
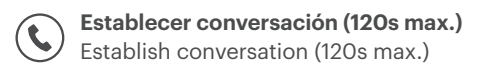
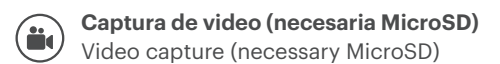
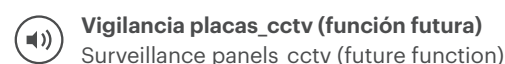
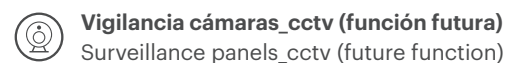
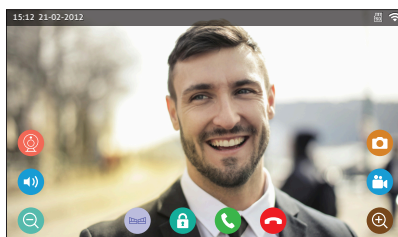
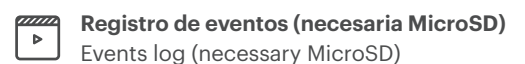
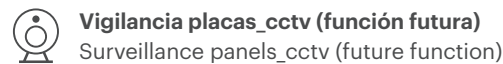
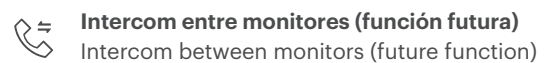
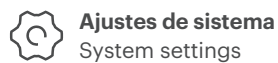
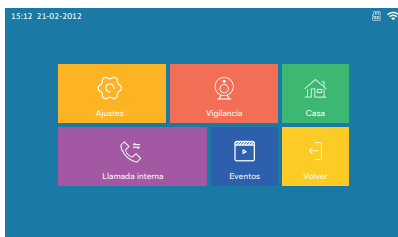
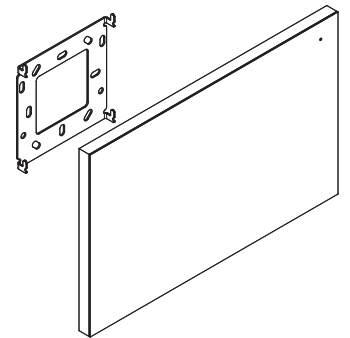
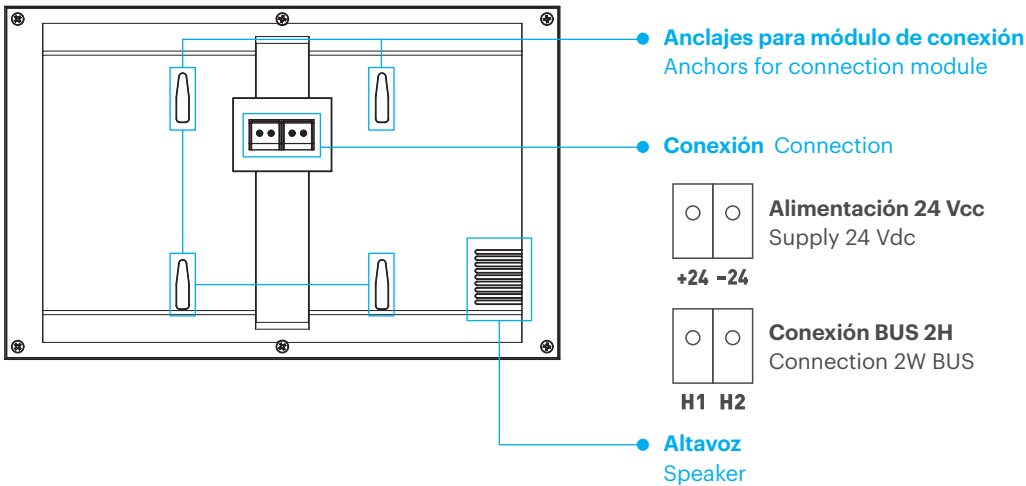
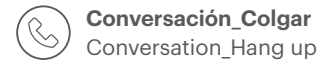
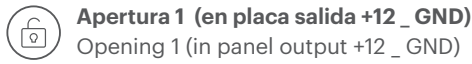
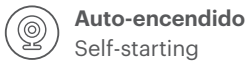
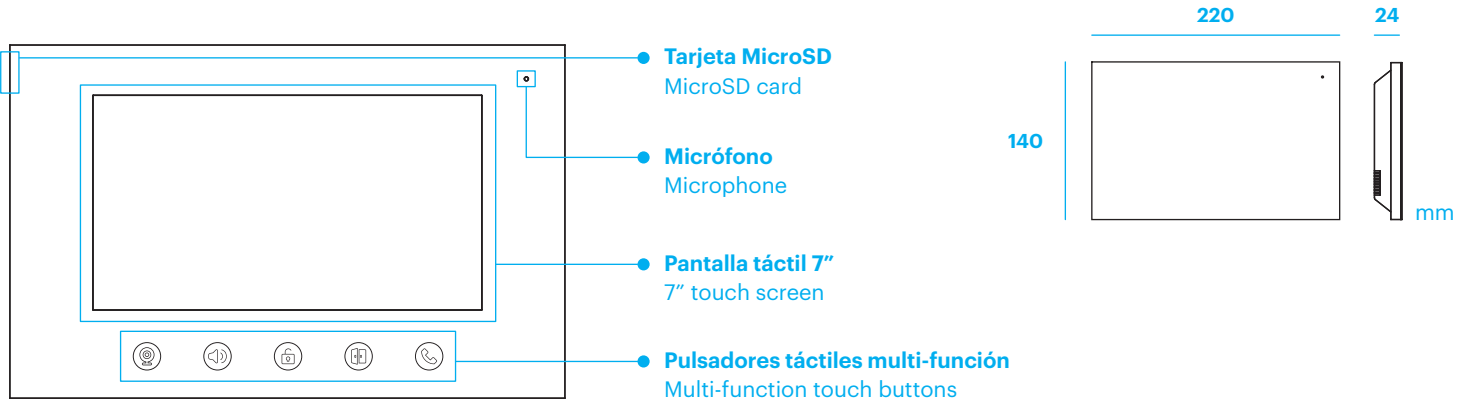

Descripción Description

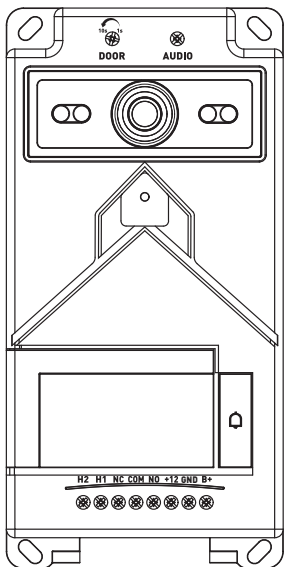

H2	Bus 2 hilos sin polaridad	2 wires bus without polarity
H1	Bus 2 hilos sin polaridad	2 wires bus without polarity
NC	Relé maniobras - Terminal 1 (1 A máximo) (controlado desde el pulsador "Puerta" del monitor)	Relay for manoeuvres - Terminal 1 (1 A maximum) (controlled by "Door" button of the monitor)
COM	Relé maniobras - Terminal 2 (1 A máximo) (controlado desde el pulsador "Puerta" del monitor)	Relay for manoeuvres - Terminal 2 (1 A maximum) (controlled by "Door" button of the monitor)
NO	Relé maniobras - Terminal 3 (1 A máximo) (controlado desde el pulsador "Puerta" del monitor)	Relay for manoeuvres - Terminal 3 (1 A maximum) (controlled by "Door" button of the monitor)
+12 *	Salida cerradura +12 Vcc (0.5 A máximo) (terminal 1)	Lock output +12 Vdc (0.5 A maximum) (terminal 1)
GND *	Salida cerradura -12 Vcc (0.5 A máximo) (terminal 2) Pulsador apertura → acciona salida +12_GND (terminal 2)	Lock output -12 Vdc (0.5 A maximum) (terminal 2) Opening button → activates +12_GND output (terminal 2)
B+	Pulsador apertura → acciona salida +12_GND (terminal 1)	Opening button → activates +12_GND output (terminal 2)
DOOR	Tiempo de apertura de 1 a 10 segundos (solo para salida NO_COM)	Opening time from 1 to 10 seconds (only for NO_COM output)
AUDIO	Volumen de audio en placa	Audio volume in outside panel

* Se puede instalar una cerradura universal 12/24 que no supere el consumo indicado.
An universal 12/24 lock that not exceed the indicated consumption can be installed.

Montaje Mounting

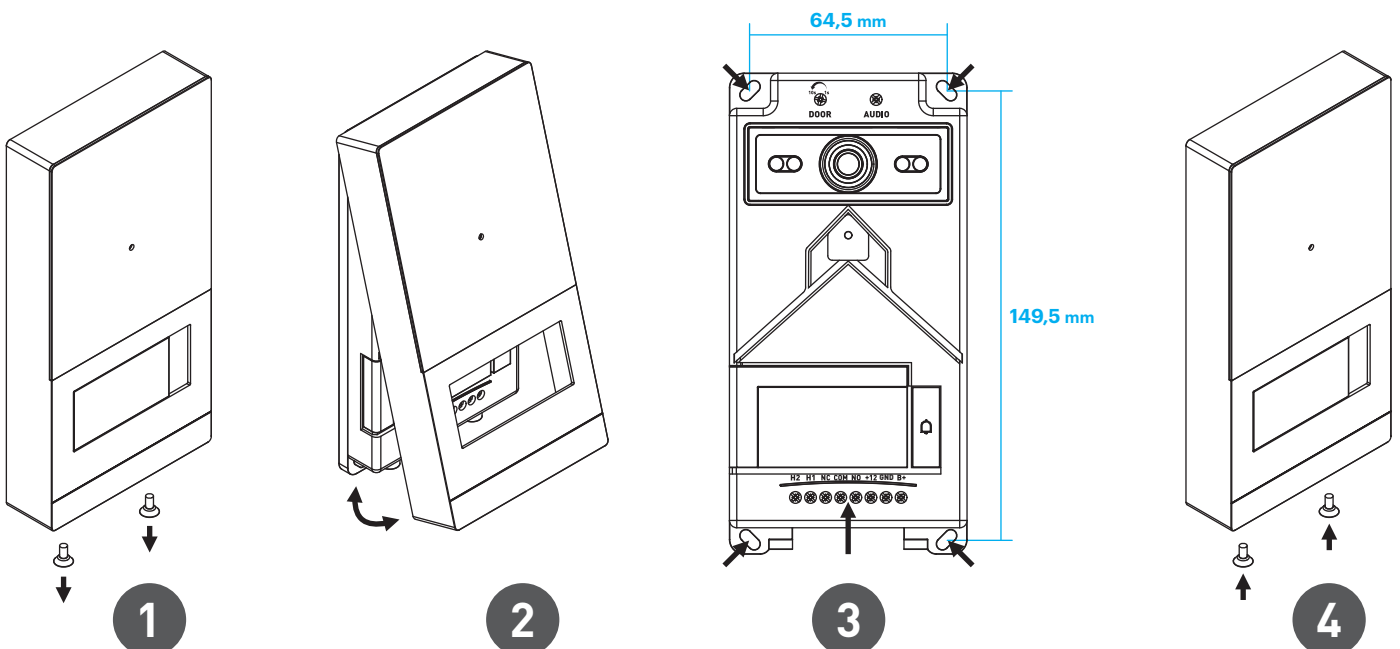

Colocar información en tarjetero Place information in the cardholder

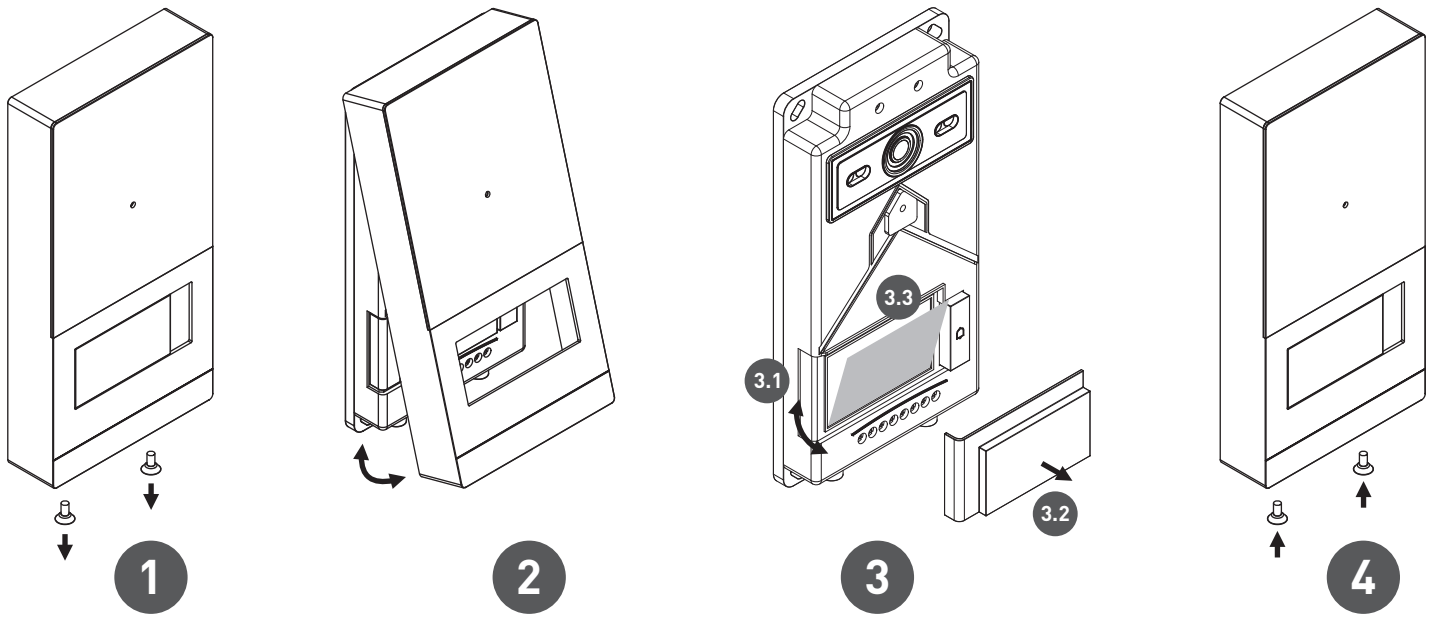

Instalación Installation



CABLE RECOMENDADO
RECOMMENDED WIRE

2 x 0,5 mm TRENZADO
2 x AWG 24 TWISTED

HASTA 150 m
UP TO 150 m

CABLE MÍNIMO RECOMENDADO
MINIMUM RECOMMENDED WIRE

2 x 0,25 mm
2 x AWG 30

HASTA 100 m
UP TO 100 m

CABLE MÁXIMO RECOMENDADO
MAXIMUM RECOMMENDED WIRE

2 x 2,5 mm
2 x AWG 10

HASTA 150 m
UP TO 150 m

Vincular monitor con APP Monitor APP pairing

1



Descargar Tuya SMART
Download Tuya SMART

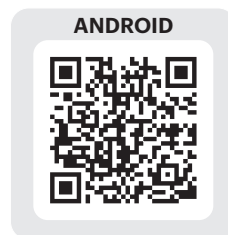

2



Conectar el monitor a la red Wi-Fi de la vivienda
Connect the monitor to the house Wi-Fi network

3



Abrir pestaña de vinculación
Seleccionar "Código QR"
Open pairing window
"Select QR code"

4

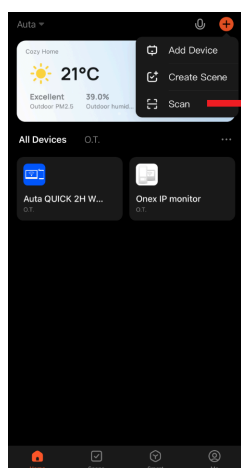

Abrir APP Tuya SMART
Añadir dispositivo
Escanear código QR
Open Tuya SMART APP
Add device
Scan QR code