

xenia

DIGITAL



REF: 680051
Coaxial
Coax

REF: 680052
No-Coax
Coaxless

REF: 680050
Visualtech 5H
Visualtech 5W

REF: 680056
2H
2W

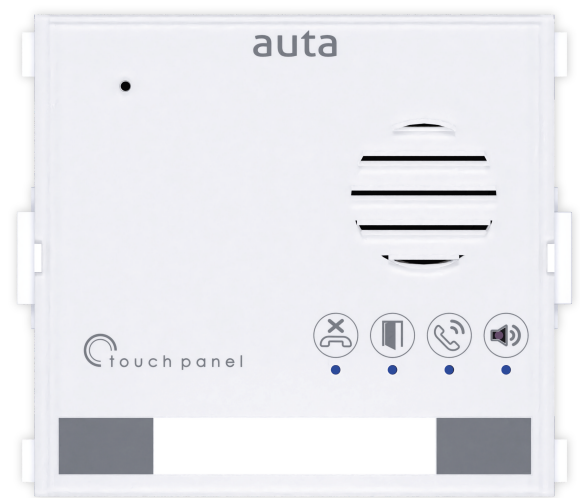

REF: 680059
Digital
Digital

REF: 680058
Visualtech 5H
Visualtech 5W

REF: 680083
2H
2W

ES MÓDULO AUDIO_VIDEO KIT

EN AUDIO_VIDEO KIT MODULE

auta

Bringing people together

Desmontaje del perfil S1, S2, S3, S4 y S5 Profile disassembly S1, S2, S3, S4 and S5

PARA UNA MAYOR COMODIDAD REALIZAR EL PROCESO USANDO UNA SUPERFICIE DE APOYO.

FOR GREATER COMFORT, PERFORM THE PROCESS USING A SUPPORT SURFACE.

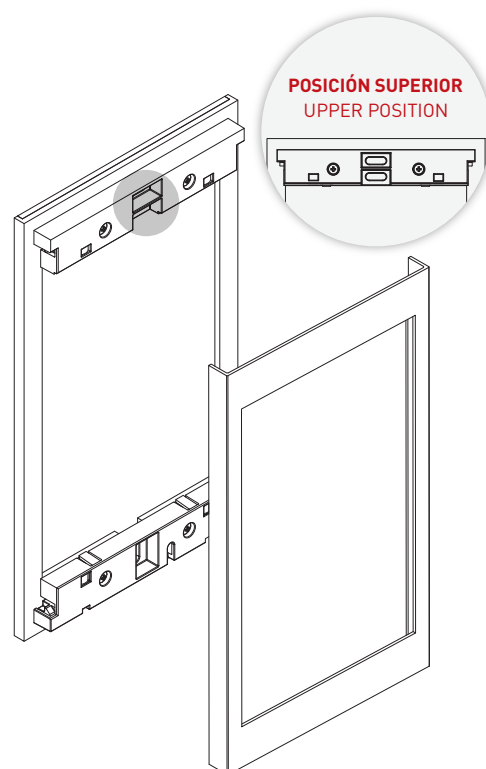
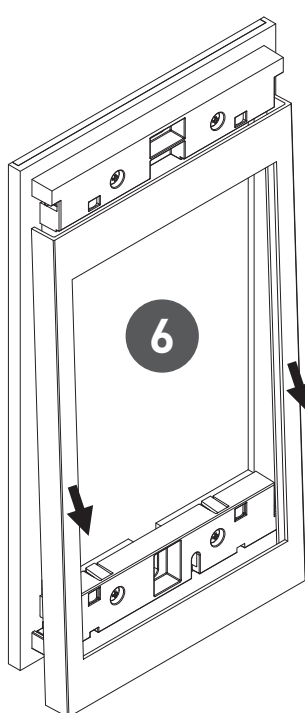
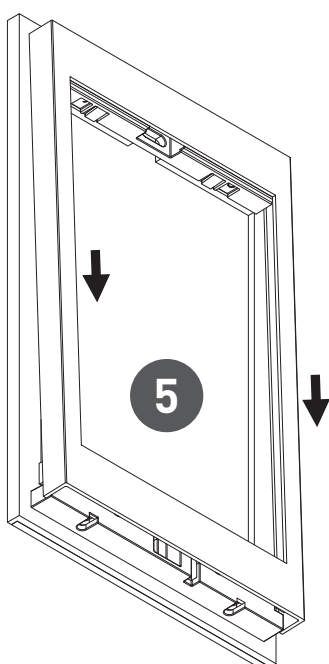
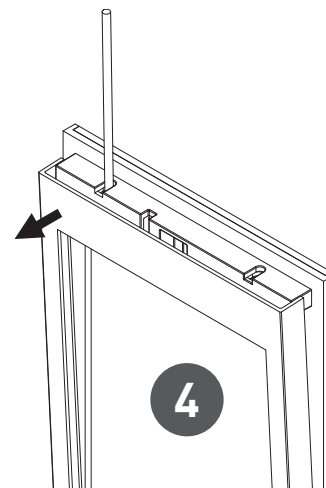
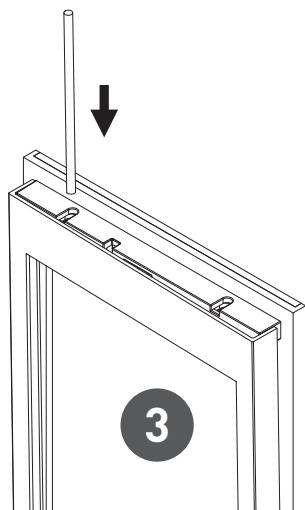
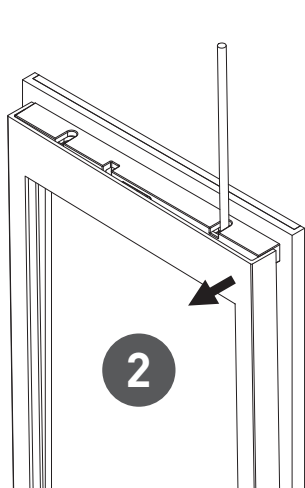
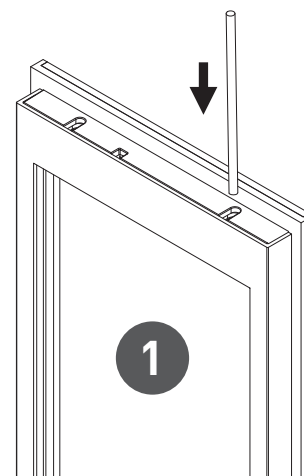
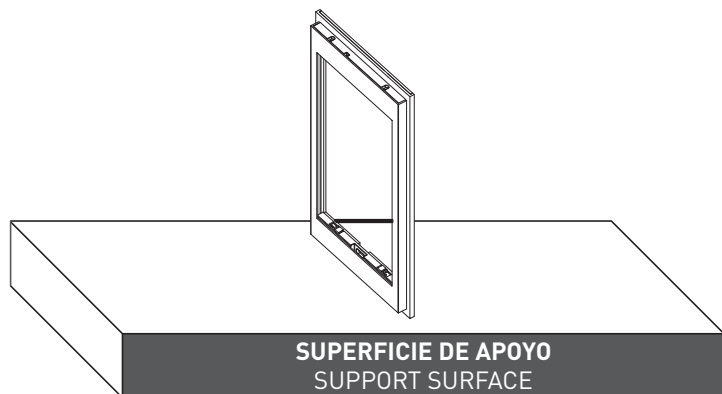

Descripción Description

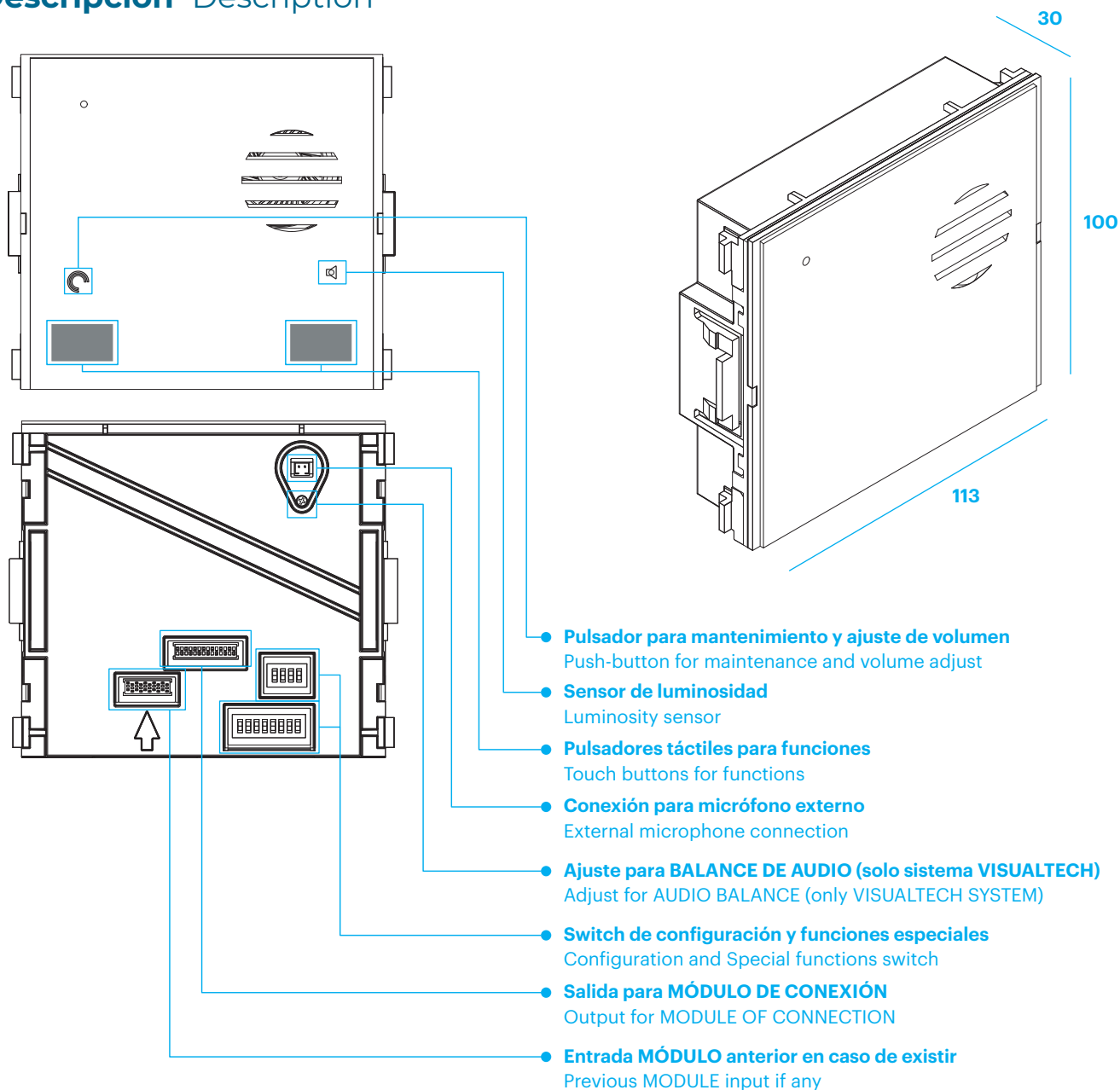

Montaje del módulo y latiguillo Module and ribbon assembly

Montar siempre en la parte SUPERIOR en placas SERIE 2, 3, 4 y 5.

Always assemble on TOP in panels SERIES 2, 3, 4 and 5.

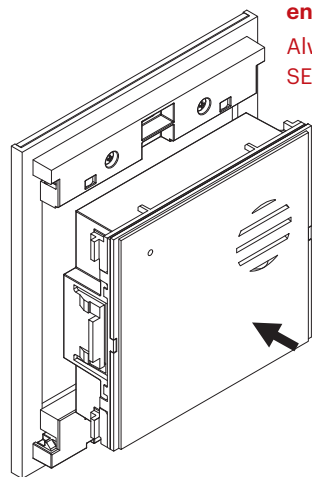

1

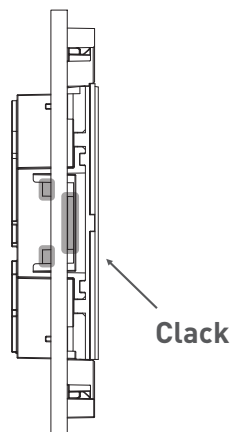

2

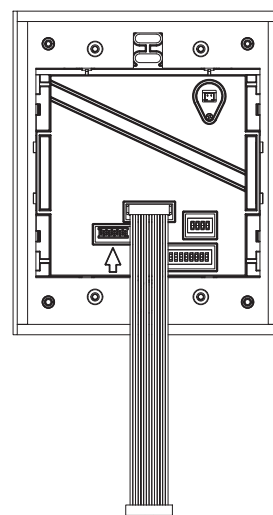

3

Configuración Configuration

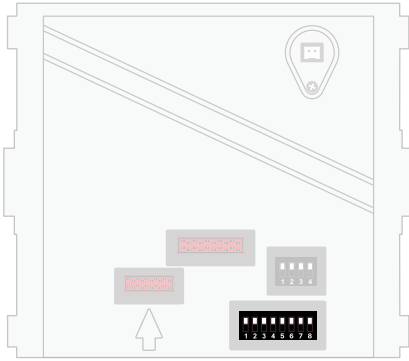

Configuración de ID de placa
Panel ID configuration

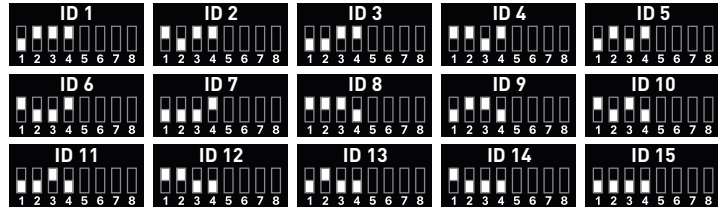

ID 0
CÓDIGO RESERVADO
la placa emitirá pitidos
si se utiliza como ID.

RESERVED CODE
the panel will emit
beeps if used as ID.



AUTO-ENCENDIDO a placa
SELF-STARTING to panel



Llamada a CONSERJERÍA
Call to CONCIERGE



SIN USO
WITHOUT USE



Mensaje "PUERTA ABIERTA"
"DOOR OPEN" message

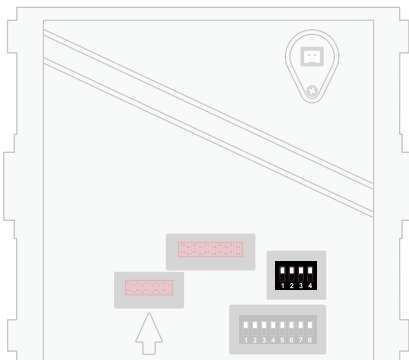

Selección PRINCIPAL _ SECUNDARIO
MASTER _ SLAVE selection



! Sistema VISUALTECH SIEMPRE OFF
VISUALTECH system ALWAYS OFF



Selección de LLAMADA
CALL selection

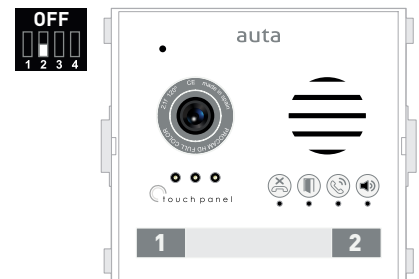
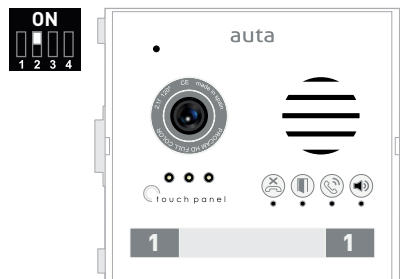

Selección de MICRÓFONO
MICROPHONE selection

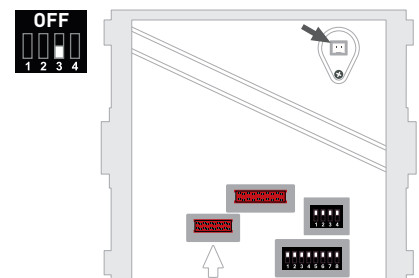
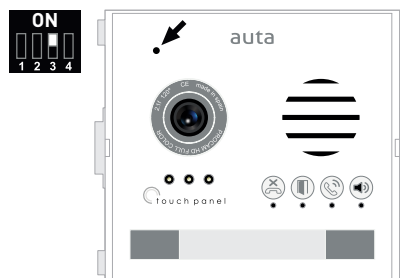

Funciones especiales
Special functions



Ajuste de volumen Volume adjust

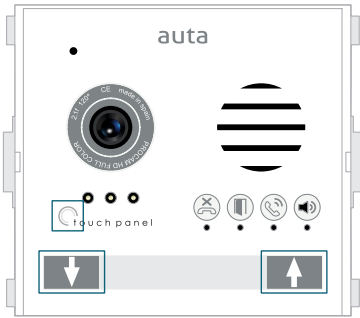

Entrar en modo ajuste de volumen Enter in volume adjust mode

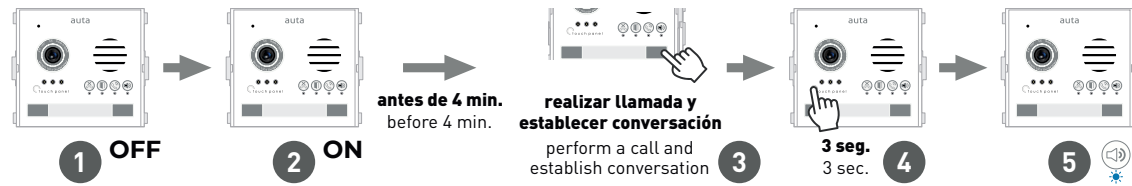

Existen 3 parámetros en los que podemos realizar ajustes de volumen:

1. Volumen de AUDIO en PLACA
2. Volumen de AUDIO en VIVIENDA
3. Volumen de AUDIO en mensaje "PUERTA ABIERTA"

Disponemos de 8 niveles de audio seleccionables, representados por 4 LEDS azules. Cada led indica 2 niveles.

There are 3 parameters in which we can make volume adjustments:

1. AUDIO volume at PANEL
2. AUDIO volume at HOUSING
3. AUDIO volume for "DOOR OPEN" message

We have 8 selectable audio levels, represented by 4 blue LEDs. Each led indicates 2 levels.

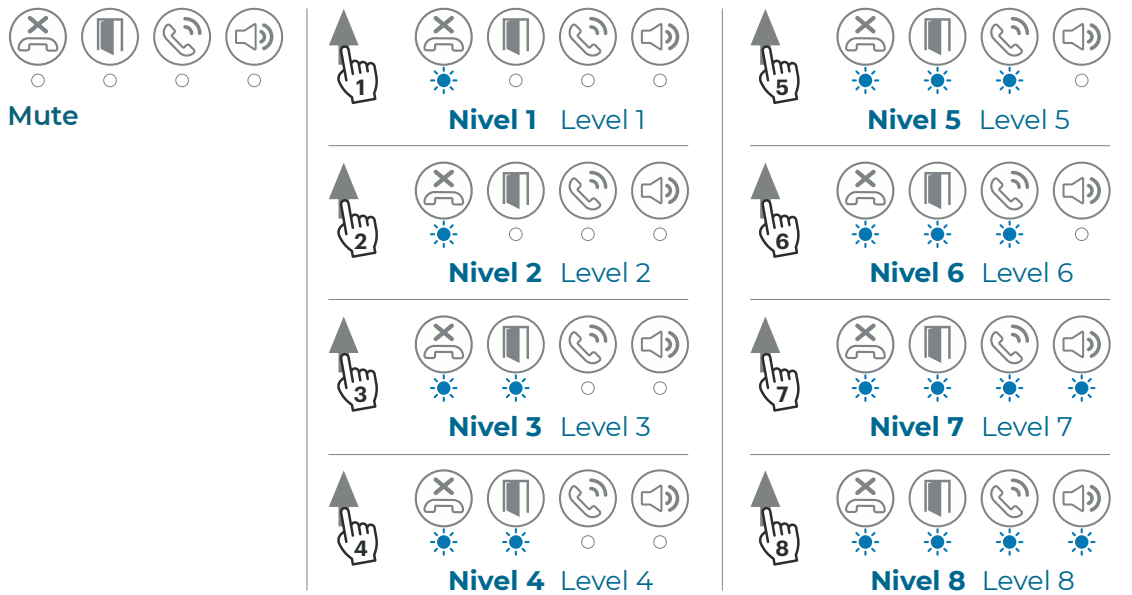

→ Ajuste de balance (solo VISUALTECH) Balance adjust (only VISUALTECH)

ESTE PROCESO SE REALIZARÁ CON TODOS LOS TERMINALES INSTALADOS Y CONECTADOS. TAMBIÉN COMPROBAREMOS QUE LA RESISTENCIA/S DE FINAL DE LÍNEA ESTÉN COLOCADAS.

Si al ajustar el volumen de audio en conversación comprobamos que se produce acoplamiento, deberemos re-ajustar LIGERAMENTE el potenciómetro de balance situado en la parte trasera del módulo Xenia.

Cada vez que modifiquemos los niveles de volumen, volveremos a re-ajustar el balance de la instalación.

THIS PROCESS WILL BE DONE WITH ALL TERMINALS INSTALLED AND CONNECTED. WE WILL ALSO CHECK THAT THE END OF LINE RESISTANCE/S ARE CONNECTED.

If when adjusting the audio volume in conversation we verify that coupling occurs, we will have to SLIGHTLY re-adjust the balance potentiometer located on the back of the Xenia module.

Every time we modify the volume levels we will readjust the balance of the installation.

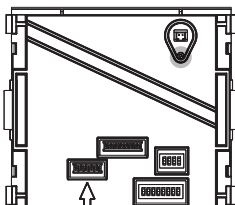

Modo mantenimiento Maintenance mode

El modo mantenimiento es un modo en el que la placa desactiva todos sus módulos conectados por seguridad, así se pueden realizar procedimientos tales como limpieza o la colocación de información en los tarjeteros de los pulsadores, con total seguridad.

El tiempo máximo en el que la placa permanece en modo mantenimiento es de 4 minutos. Pasado este tiempo se deberá re-armar.

The maintenance mode is a mode in which the panel deactivates all its connected modules for safety reasons, so procedures such as cleaning or placing information in the button card holders, can be carried out in complete safety.

The maximum time that the panel remains in maintenance mode is 4 minutes. After this time, it must be re-armed.

Entrar en modo mantenimiento Enter in maintenance mode

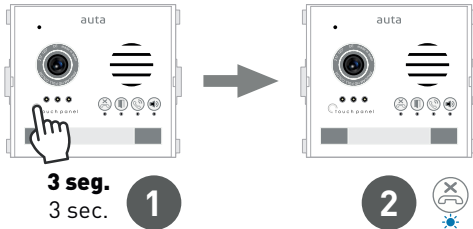

Colocar información en tarjetero Place information in card holder

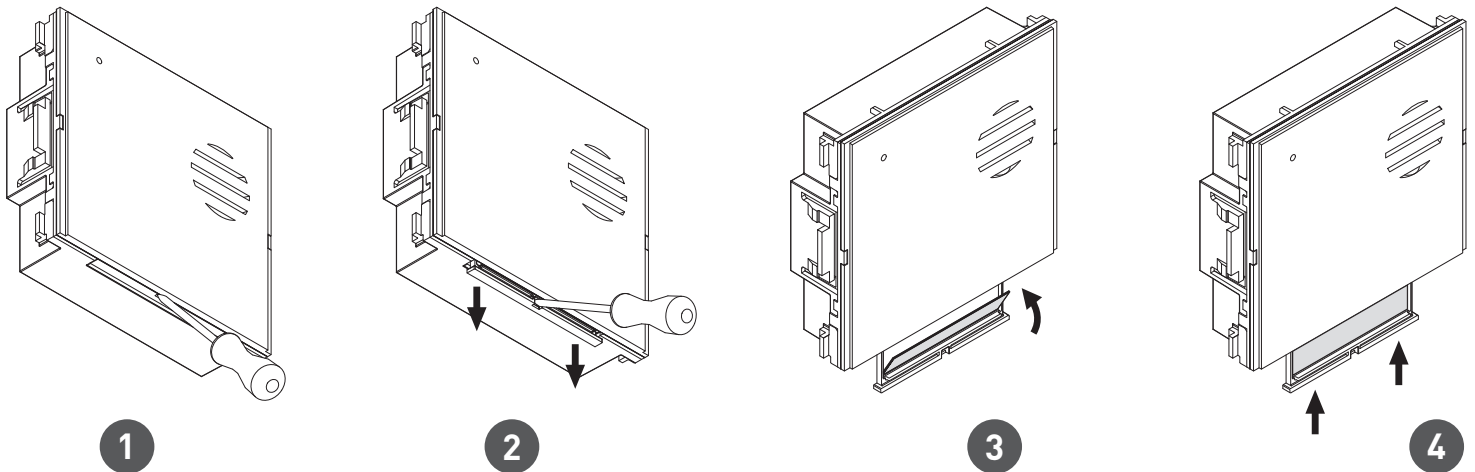

Desmontaje de módulos Modules unmount

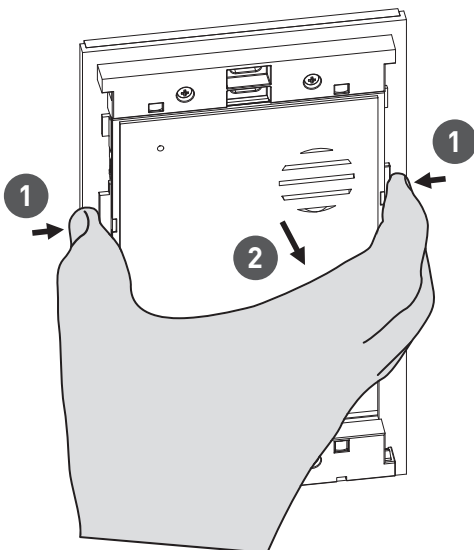

NO USAR DESTORNILLADOR O SIMILAR
DON'T USE SCREW DRIVER OR SIMILAR

Montaje del perfil S1, S2, S3, S4 y S5 Profile assembly S1, S2, S3, S4 and S5

