

neos



REF: 743134

ES KF-2 S1 2 HLOS

EN KF-2 S1 2 WIRES

auta

Bringing people together

Desmontaje del perfil S1, S2, S3, S4 y S5 Profile disassembly S1, S2, S3, S4 and S5

PARA UNA MAYOR COMODIDAD REALIZAR EL PROCESO USANDO UNA SUPERFICIE DE APOYO.

FOR GREATER COMFORT, PERFORM THE PROCESS USING A SUPPORT SURFACE.

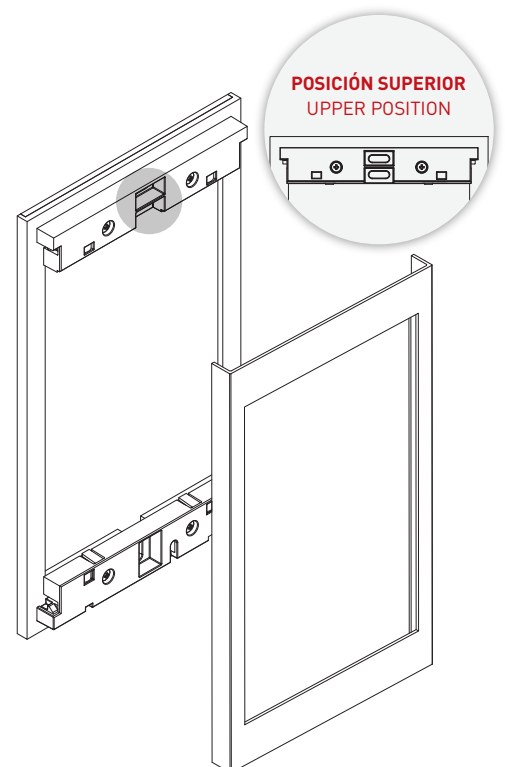
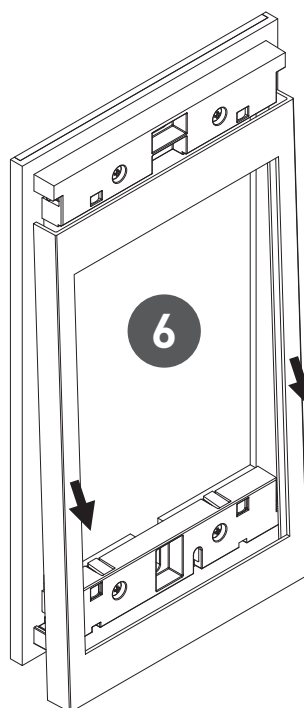
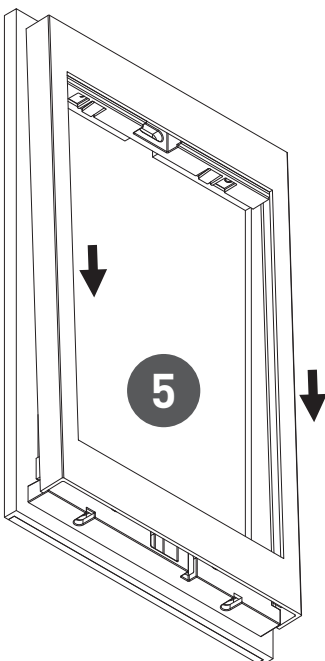
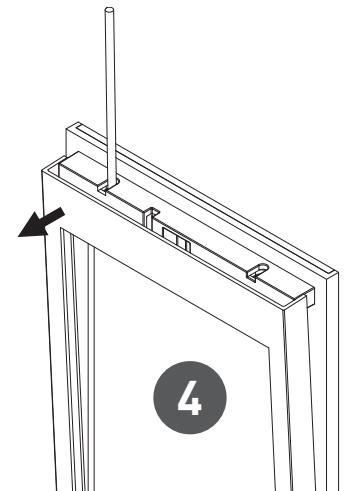
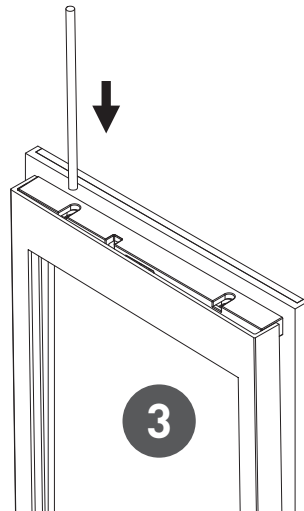
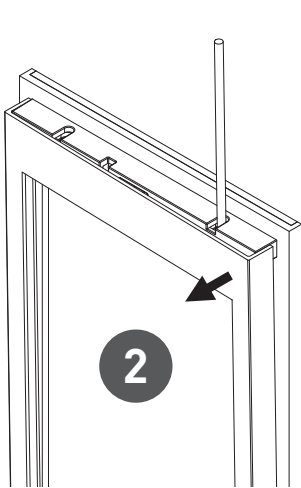
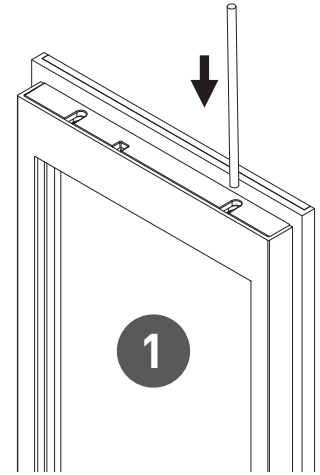
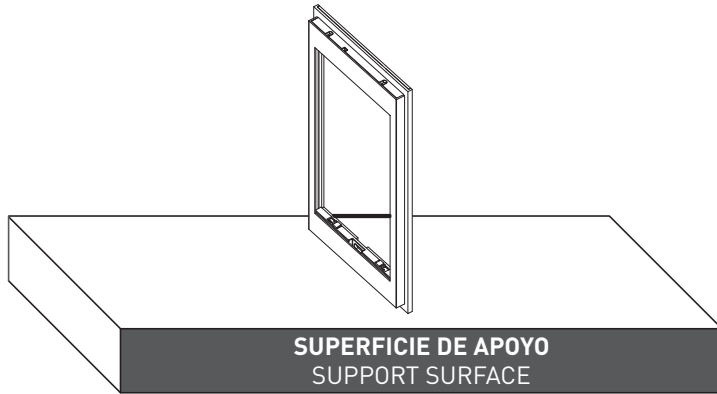

Elementos en el kit Elements in the kit



x1

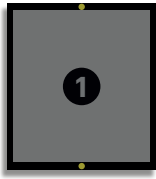

x1



x2



x1



x1



x1



x1

Colocar información en tarjetero Place information in card holder

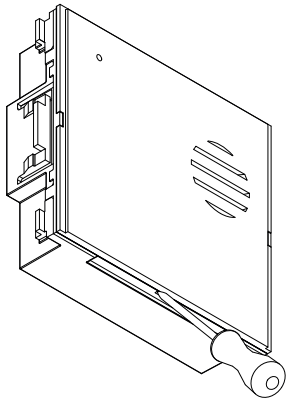

1

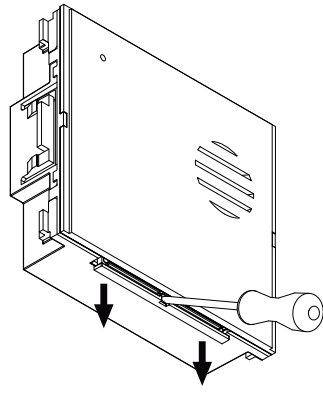

2

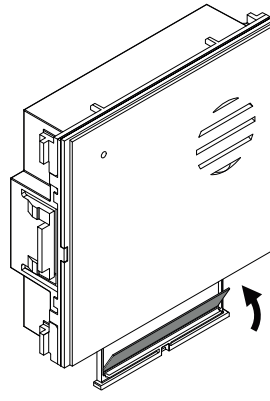

3

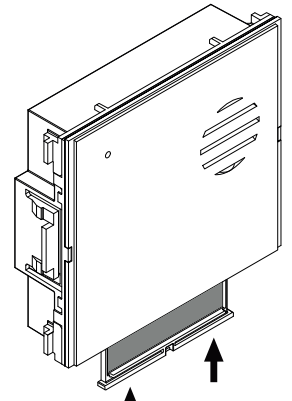

4

Descripción Description

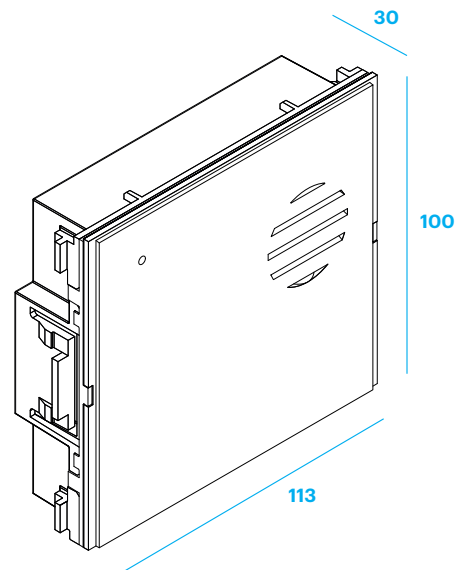
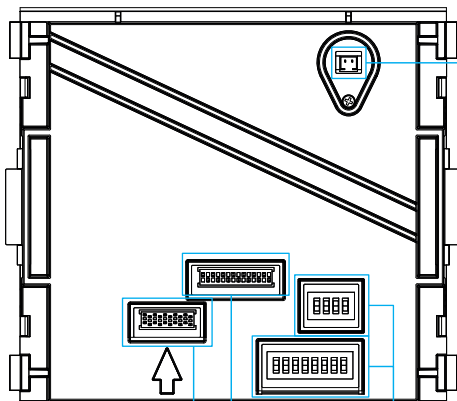
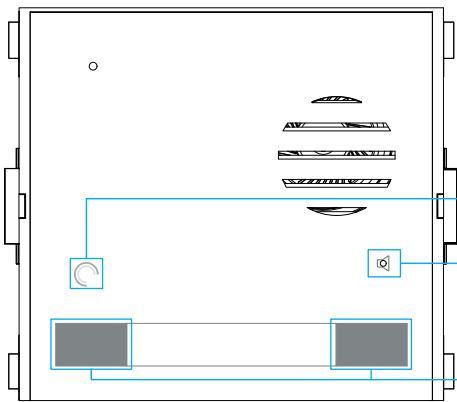

- **Pulsador para mantenimiento y ajuste de volumen**
Push-button for maintenance and volume adjust
- **Sensor de luminosidad**
Luminosity sensor
- **Pulsadores táctiles para funciones**
Touch buttons for functions
- **Conexión para micrófono externo**
External microphone connection
- **Switch de configuración y funciones especiales**
Configuration and Special functions switch
- **Salida para MÓDULO DE CONEXIÓN**
Output for MODULE OF CONNECTION
- **Entrada MÓDULO anterior en caso de existir**
Previous MODULE input if any



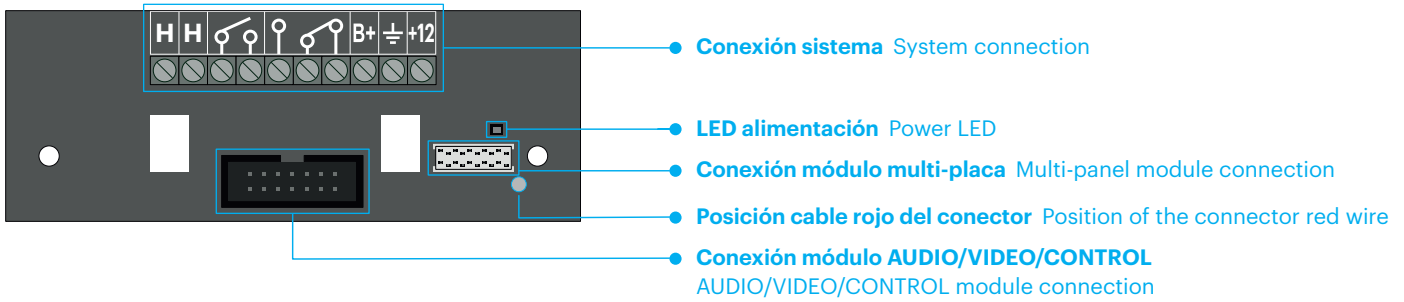

H	BUS 2H (canal A)	2W BUS (channel A)
H	BUS 2H (canal B)	2W BUS (channel B)
	Relé 1 libre de tensión N.A. _1A	Free tension N.O. _1A relay 1
	Relé 2 libre de tensión N.A. - N.C. _1A (conmutará al recibir un comando de tecla AUX)	Free tension N.O. - N.C. _1A relay 2 (will switch when receives a command from AUX button)
B+	Pulsador apertura (terminal 1)	Opening button (terminal 1)
	Pulsador apertura (terminal 2) -12 Vcc	Opening button (terminal 2) -12 Vdc
+12	+12 Vcc	+12 Vdc

* Solo monitores_teléfonos que incluyan esta función.
Su funcionamiento se podrá cambiar conectando un Teclado + Display.

* Only monitors_telephones that includes that function.
Its functioning can be changed by connecting a Keypad + Display

Instalación Installation

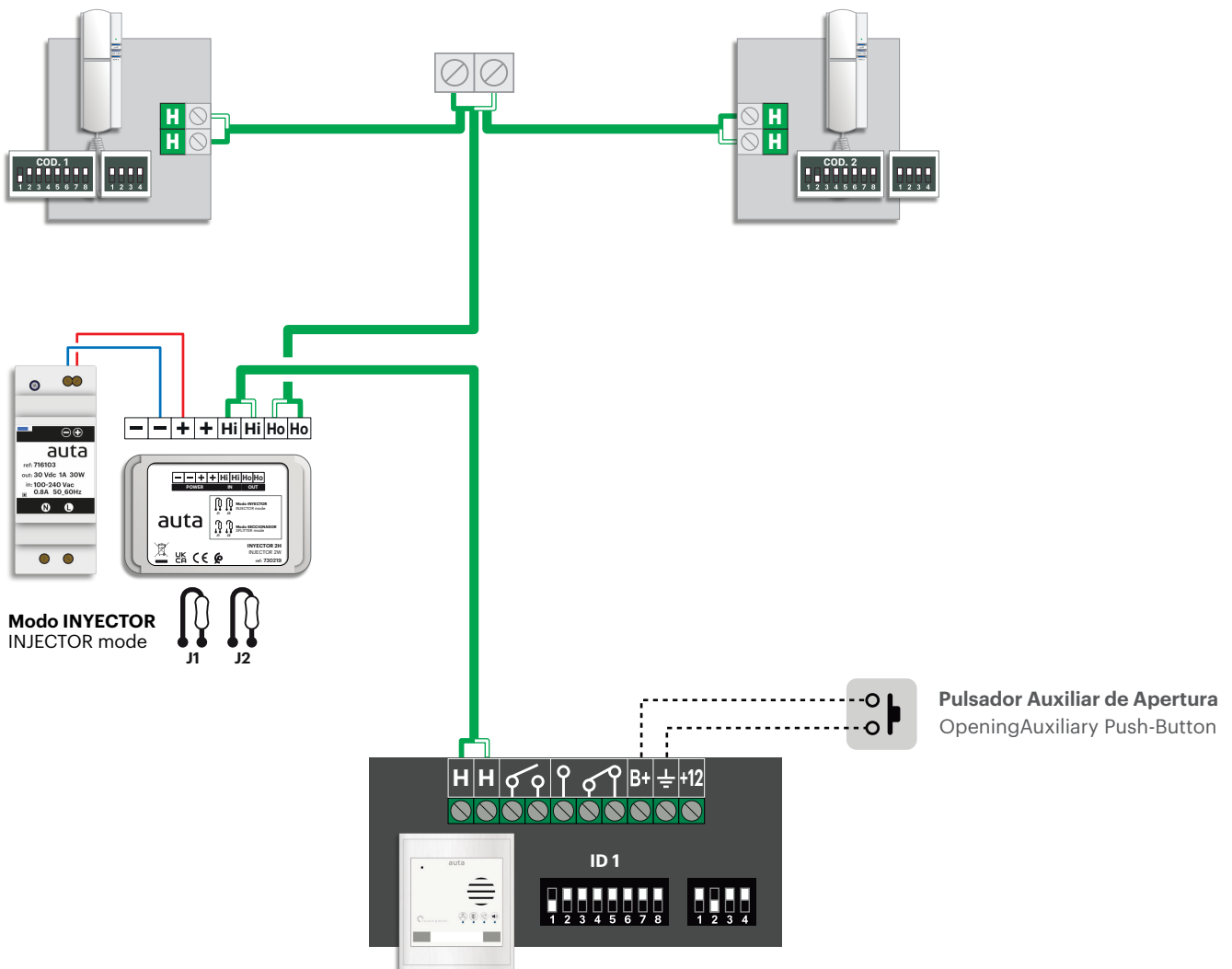

Configuración Configuration

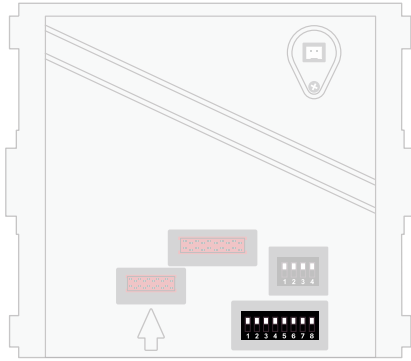

Configuración de ID de placa Panel ID configuration

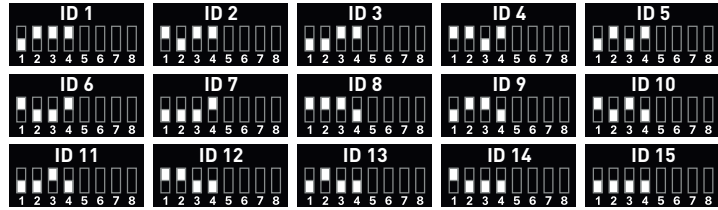

ID 0
1 2 3 4 5 6 7 8

CÓDIGO RESERVADO
la placa emitirá pitidos si se utiliza como ID.

RESERVED CODE
the panel will emit beeps if used as ID.



AUTO-ENCENDIDO a placa SELF-STARTING to panel



Llamada a CONSERJERÍA Call to CONCIERGE



SIN USO WITHOUT USE



Mensaje "PUERTA ABIERTA" "DOOR OPEN" message

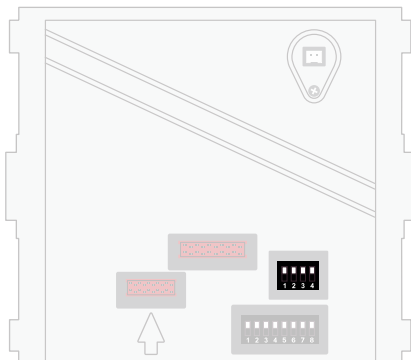

Selección PRINCIPAL _ SECUNDARIO MASTER _ SLAVE selection



Selección de LLAMADA CALL selection

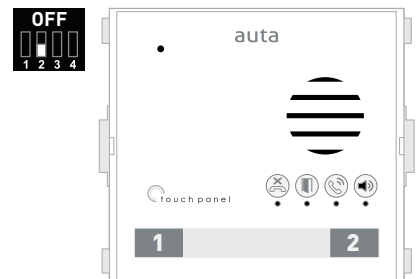
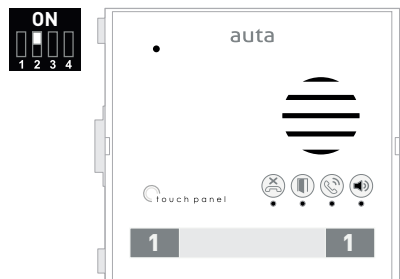

Selección de MICRÓFONO MICROPHONE selection

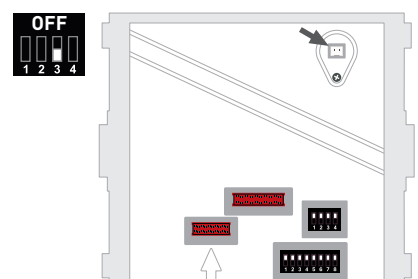
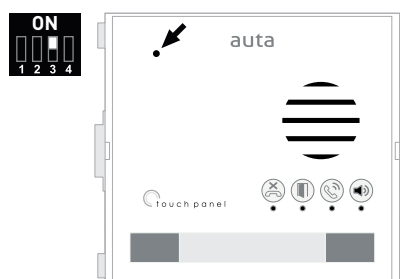

Funciones especiales Special functions



MONTAJE MOUNTING



Ajuste de volumen Volume adjust

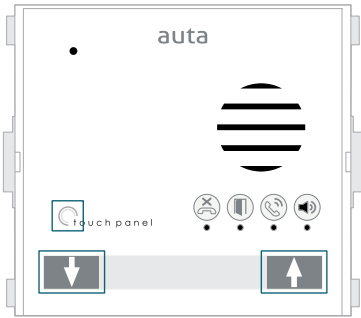

Entrar en modo ajuste de volumen Enter in volume adjust mode

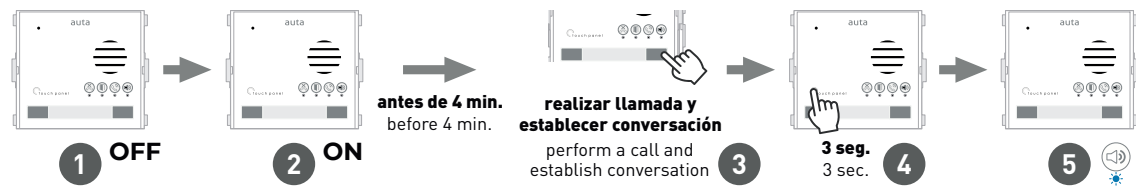

Existen 3 parámetros en los que podemos realizar ajustes de volumen:

1. Volumen de AUDIO en PLACA
2. Volumen de AUDIO en VIVIENDA
3. Volumen de AUDIO en mensaje "PUERTA ABIERTA"

Disponemos de 8 niveles de audio seleccionables, representados por 4 LEDS azules. Cada led indica 2 niveles.

There are 3 parameters in which we can make volume adjustments:

1. AUDIO volume at PANEL
2. AUDIO volume at HOUSING
3. AUDIO volume for "DOOR OPEN" message

We have 8 selectable audio levels, represented by 4 blue LEDs. Each led indicates 2 levels.

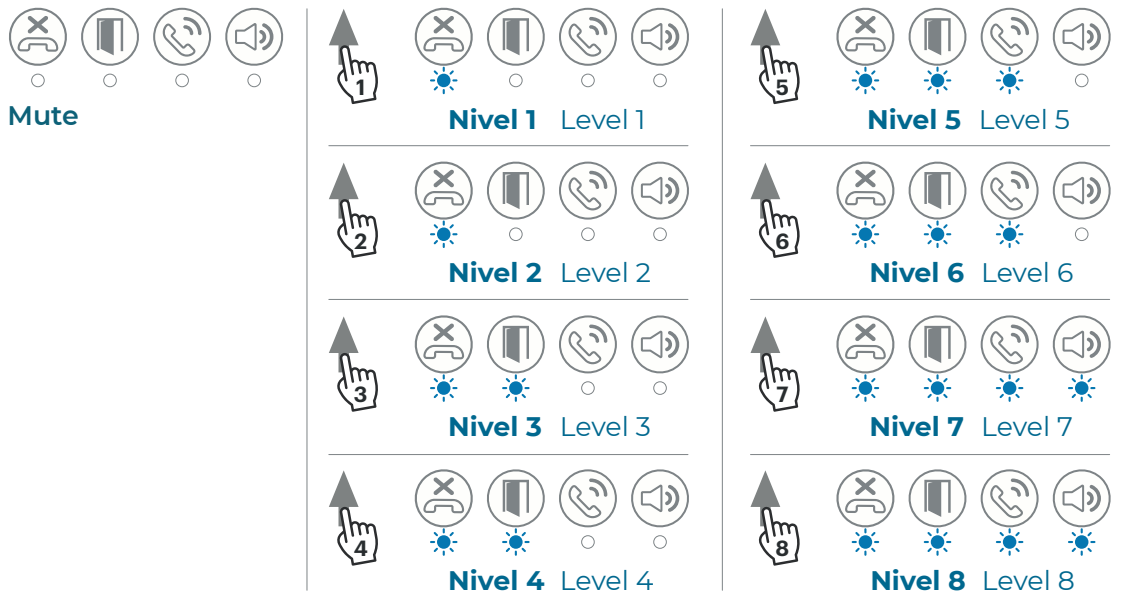

Modo mantenimiento Maintenance mode

El modo mantenimiento es un modo en el que la placa desactiva todos sus módulos conectados por seguridad, así se pueden realizar procedimientos tales como limpieza o la colocación de información en los tarjeteros de los pulsadores, con total seguridad.

El tiempo máximo en el que la placa permanece en modo mantenimiento es de 4 minutos. Pasado este tiempo se deberá re-armar.

The maintenance mode is a mode in which the panel deactivates all its connected modules for safety reasons, so procedures such as cleaning or placing information in the button card holders, can be carried out in complete safety.

The maximum time that the panel remains in maintenance mode is 4 minutes. After this time, it must be re-armed.

Entrar en modo mantenimiento Enter in maintenance mode

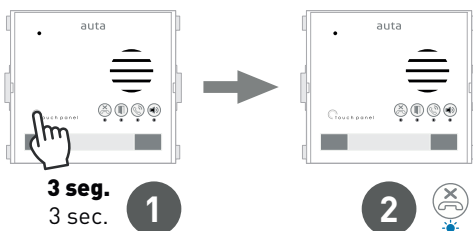

Montaje Mounting

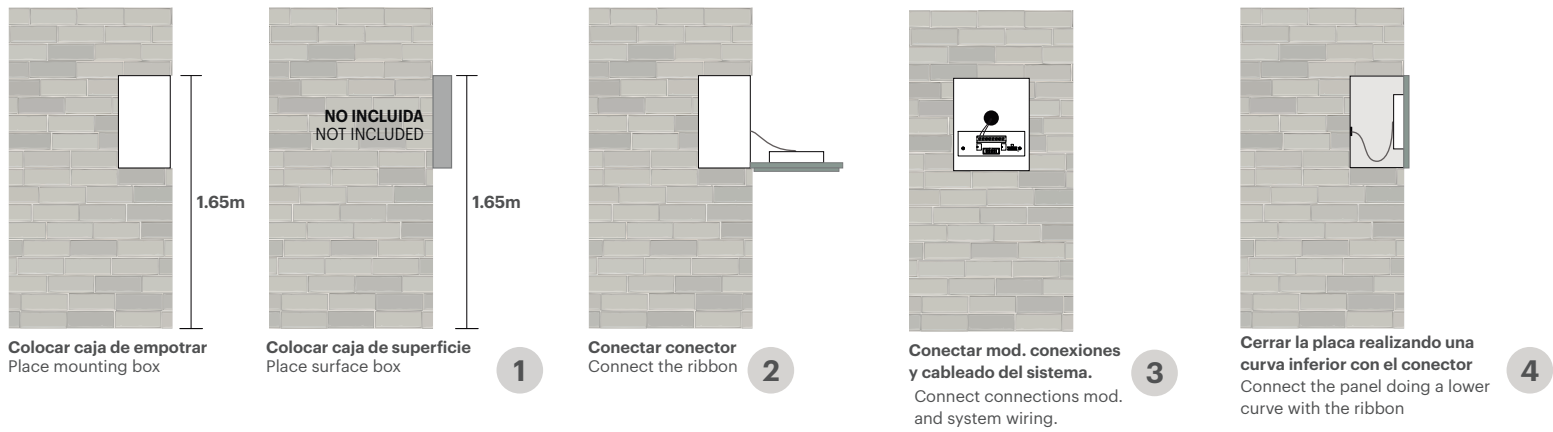

Montaje del perfil S1, S2, S3, S4 y S5 Profile assembly S1, S2, S3, S4 and S5

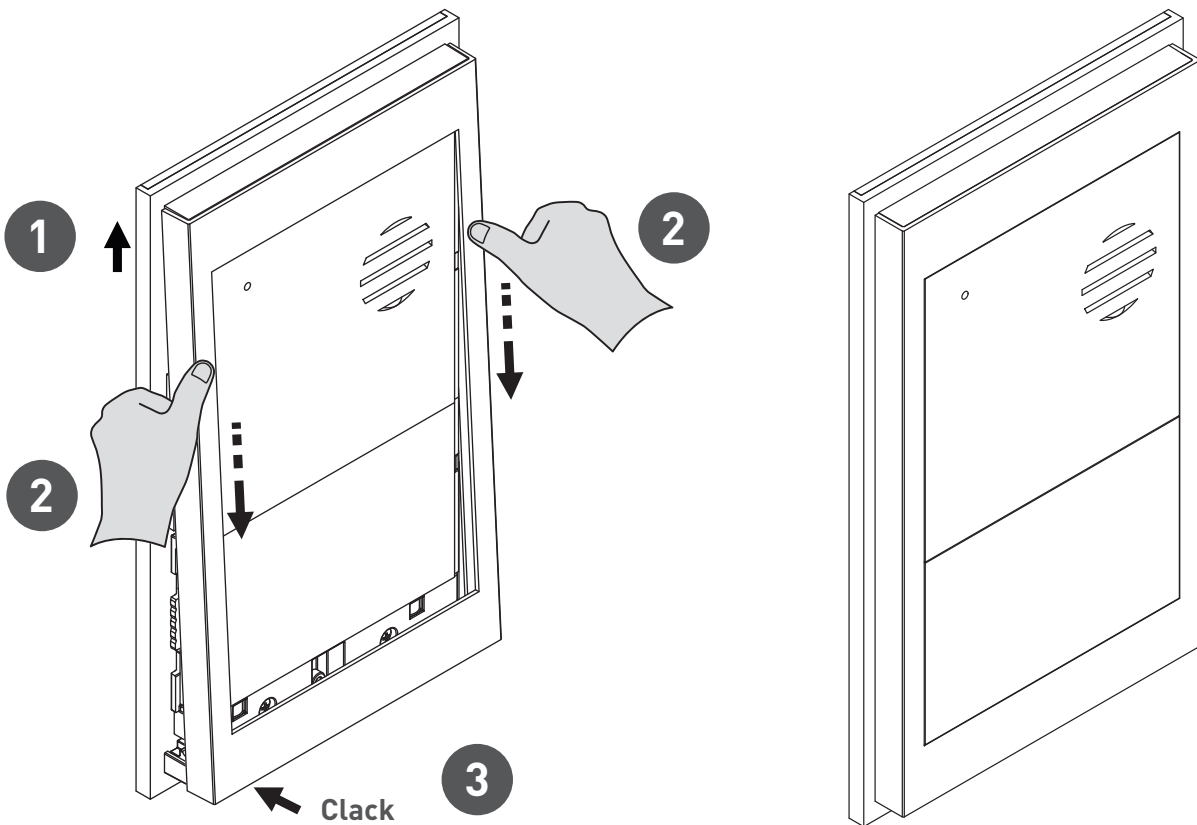

ELEMENTOS UNITS	ALV-1A (716103)
 LLAMADA SIMULTANEA SIMULTANEOUS CALL	3

GESTIÓN DE ABREPUERTAS DOOR OPENER MANAGEMENT

