

neos

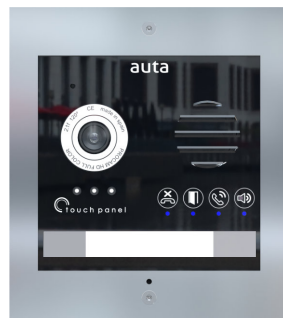

REF: 745013



REF: 745014

ES KVD-1 S1 2 HILOS Wi-Fi

EN KVD-1 S1 2 WIRES Wi-Fi

auta

Bringing people together

Elementos en el kit Elements in the kit

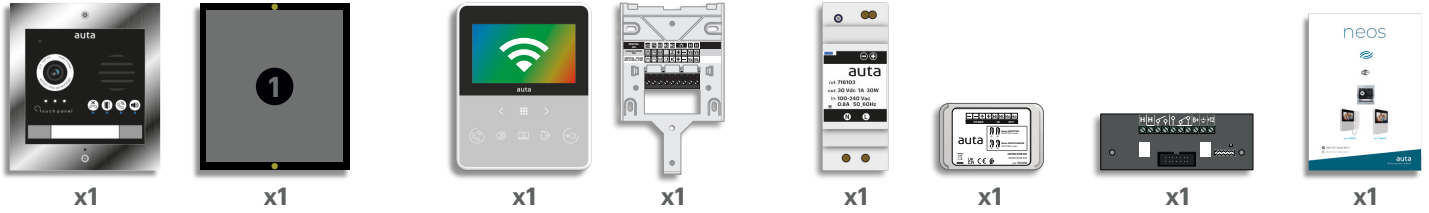

Colocar información en tarjetero Place information in card holder

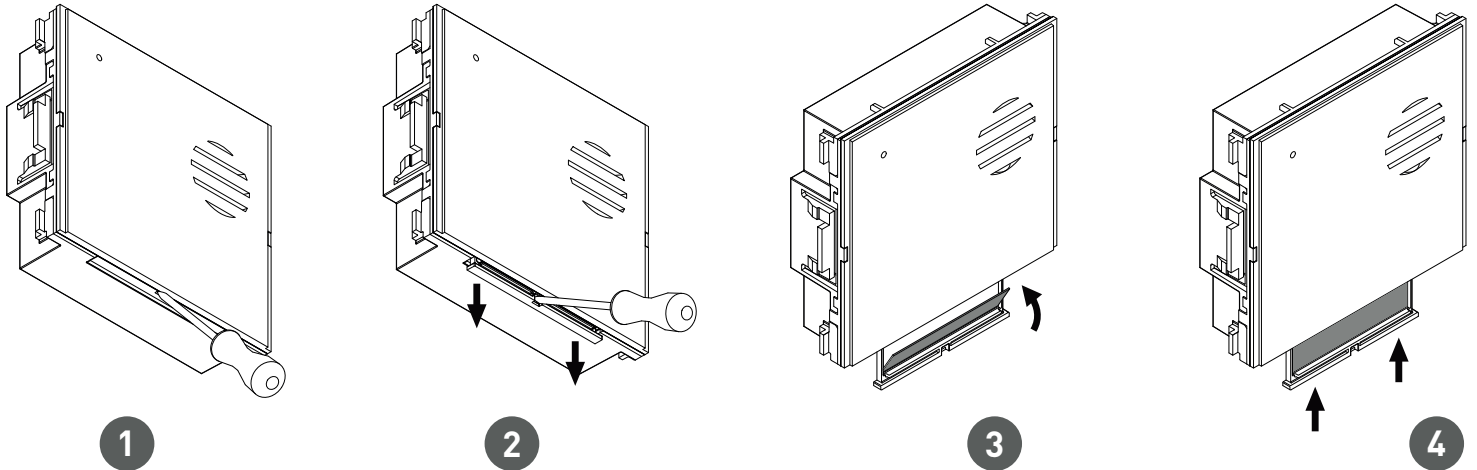

Descripción Description

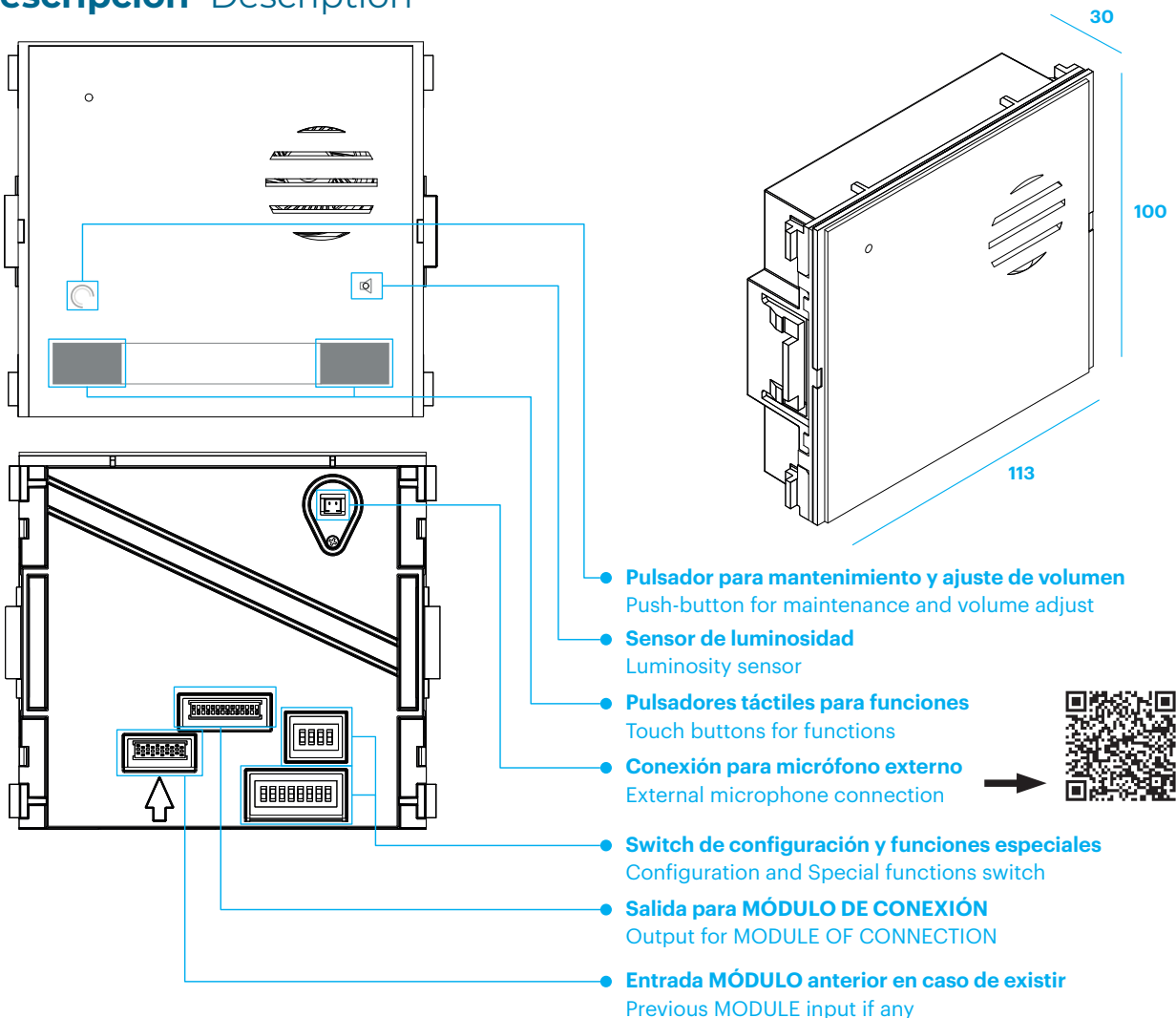

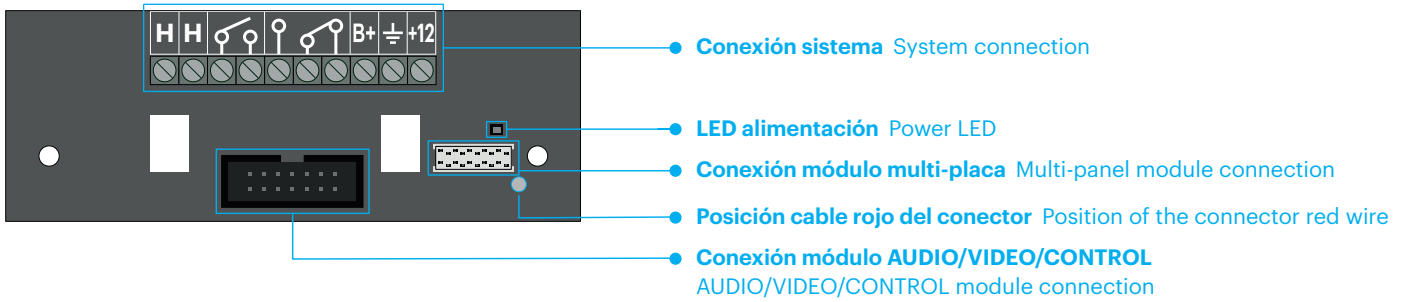

H	BUS 2H (canal A)	2W BUS (channel A)
H	BUS 2H (canal B)	2W BUS (channel B)
	Relé 1 libre de tensión N.A. _1A	Free tension N.O. _1A relay 1
	Relé 2 libre de tensión N.A. - N.C. _1A (conmutará al recibir un comando de tecla AUX)	Free tension N.O. - N.C. _1A relay 2 (will switch when receives a command from AUX button)
B+	Pulsador apertura (terminal 1)	Opening button (terminal 1)
	Pulsador apertura (terminal 2) -12 Vcc	Opening button (terminal 2) -12 Vdc
+12	+12 Vcc	+12 Vdc

* Solo monitores_teléfonos que incluyan esta función.
Su funcionamiento se podrá cambiar conectando un Teclado + Display.

* Only monitors_telephones that includes that function.
Its functioning can be changed by connecting a Keypad + Display

Instalación Installation

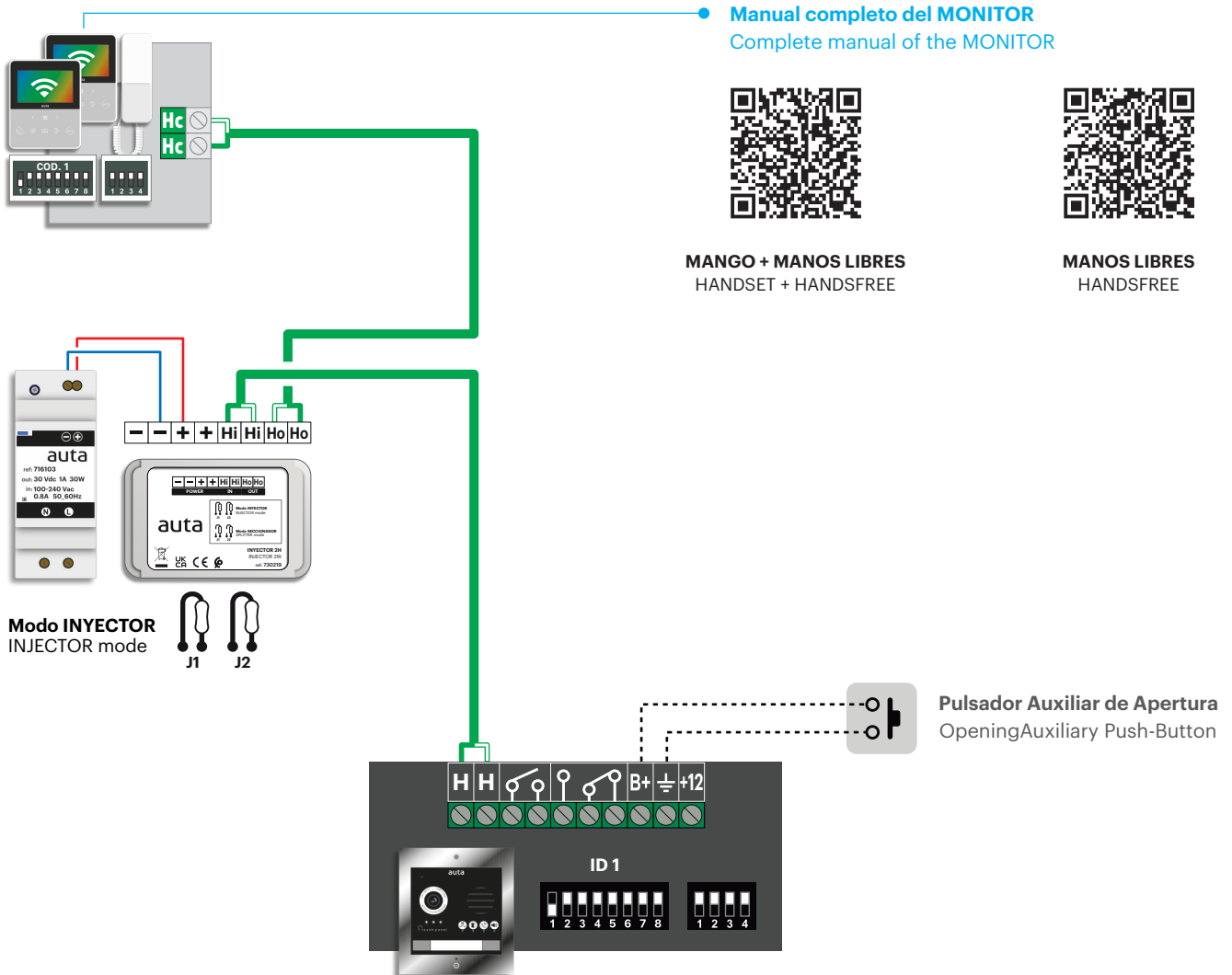

Configuración Configuration

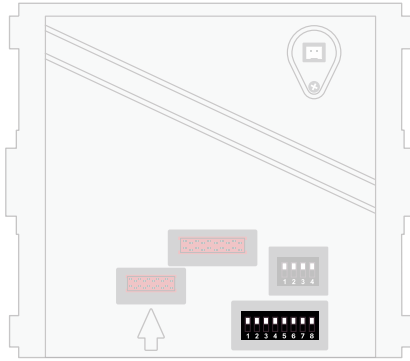

Configuración de ID de placa Panel ID configuration

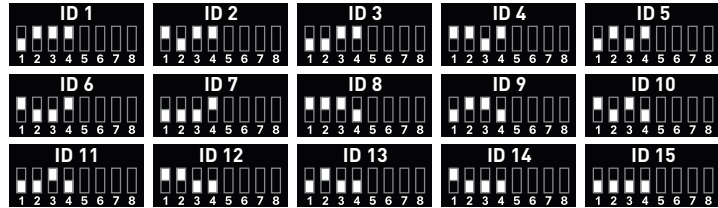

CÓDIGO RESERVADO
la placa emitirá pitidos
si se utiliza como ID.

RESERVED CODE
the panel will emit
beeps if used as ID.



AUTO-ENCENDIDO a placa SELF-STARTING to panel



Llamada a CONSERJERÍA Call to CONCIERGE



SIN USO WITHOUT USE



Mensaje "PUERTA ABIERTA" "DOOR OPEN" message

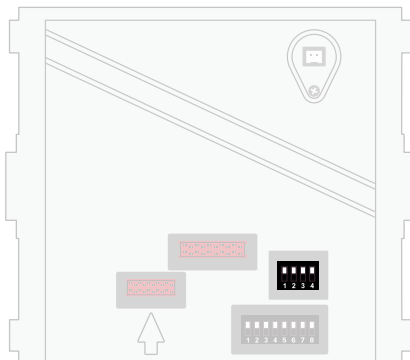

Selección PRINCIPAL _ SECUNDARIO MASTER _ SLAVE selection



Selección de LLAMADA CALL selection

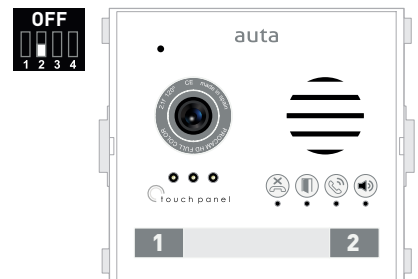
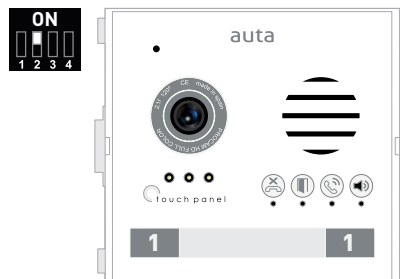

Selección de MICRÓFONO MICROPHONE selection

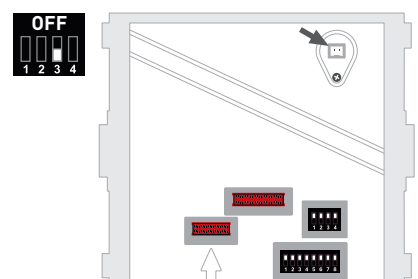
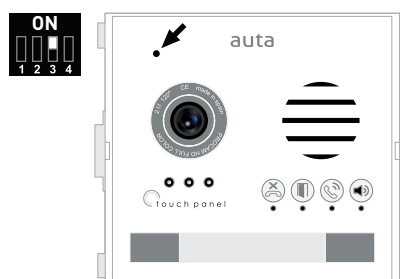

Funciones especiales Special functions



MONTAJE MOUNTING



Ajuste de volumen Volume adjust

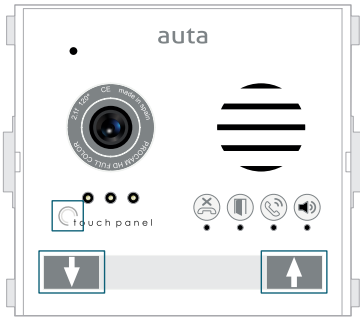

Entrar en modo ajuste de volumen Enter in volume adjust mode

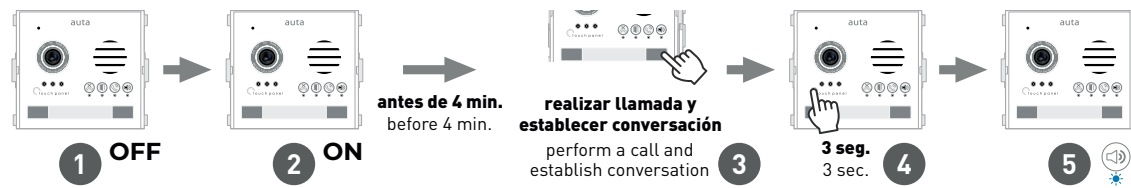

Existen 3 parámetros en los que podemos realizar ajustes de volumen:

1. Volumen de AUDIO en PLACA
2. Volumen de AUDIO en VIVIENDA
3. Volumen de AUDIO en mensaje "PUERTA ABIERTA"

Disponemos de 8 niveles de audio seleccionables, representados por 4 LEDS azules. Cada led indica 2 niveles.

There are 3 parameters in which we can make volume adjustments:

1. AUDIO volume at PANEL
2. AUDIO volume at HOUSING
3. AUDIO volume for "DOOR OPEN" message

We have 8 selectable audio levels, represented by 4 blue LEDs. Each led indicates 2 levels.

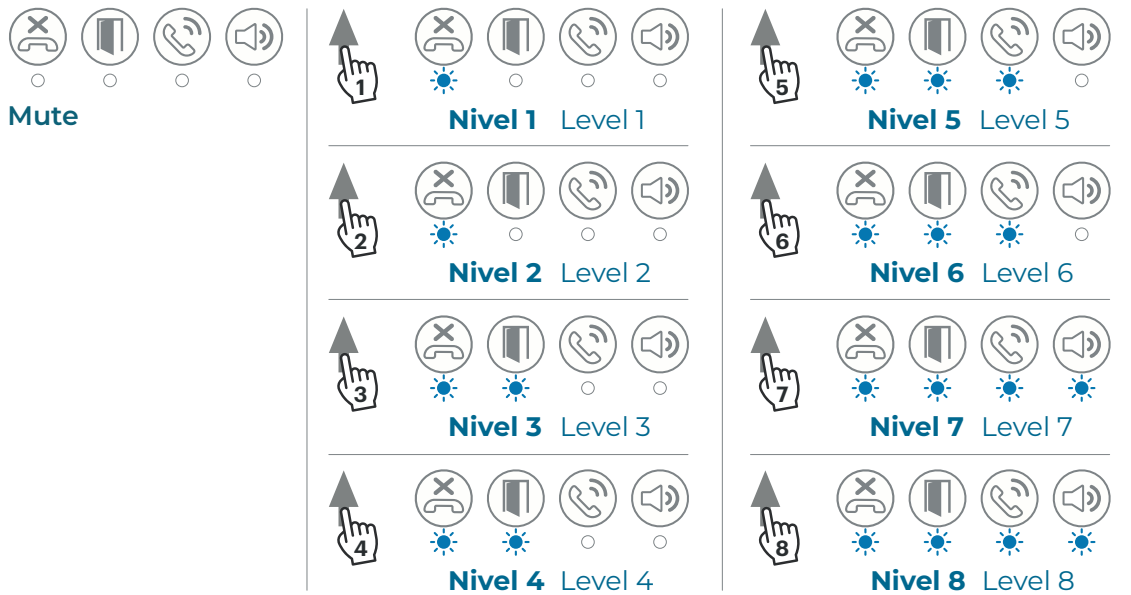

Modo mantenimiento Maintenance mode

El modo mantenimiento es un modo en el que la placa desactiva todos sus módulos conectados por seguridad, así se pueden realizar procedimientos tales como limpieza o la colocación de información en los tarjeteros de los pulsadores, con total seguridad.

El tiempo máximo en el que la placa permanece en modo mantenimiento es de 4 minutos. Pasado este tiempo se deberá re-armar.

The maintenance mode is a mode in which the panel deactivates all its connected modules for safety reasons, so procedures such as cleaning or placing information in the button card holders, can be carried out in complete safety.

The maximum time that the panel remains in maintenance mode is 4 minutes. After this time, it must be re-armed.

Entrar en modo mantenimiento Enter in maintenance mode

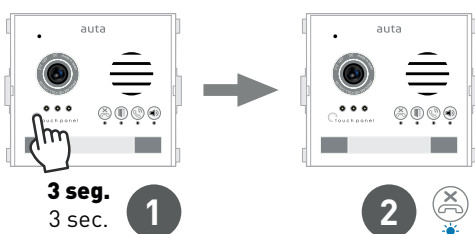

Montaje Mounting

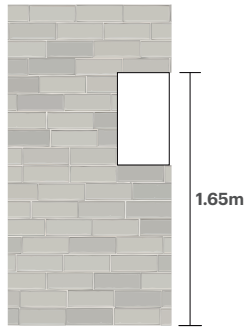

Colocar caja de empotrar
Place mounting box

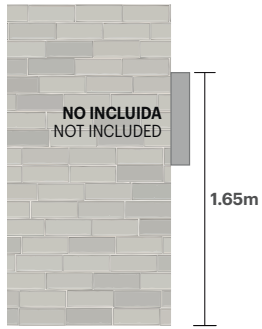

Colocar caja de superficie
Place surface box

1

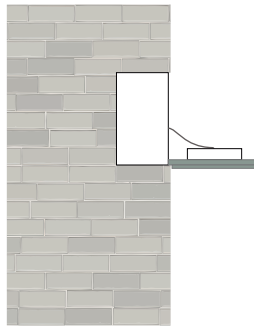

Conectar conector
Connect the ribbon

2

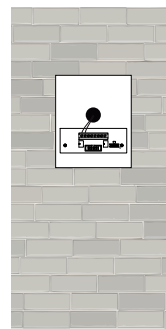

Conectar mod. conexiones
y cableado del sistema.

Connect connections mod.
and system wiring.

3

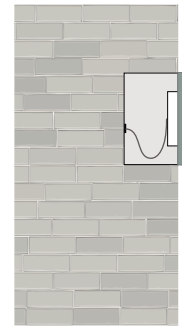

Cerrar la placa realizando una
curva inferior con el conector

Connect the panel doing a lower
curve with the ribbon

4

Selección de idioma Language selection



Vinculación Pairing



1

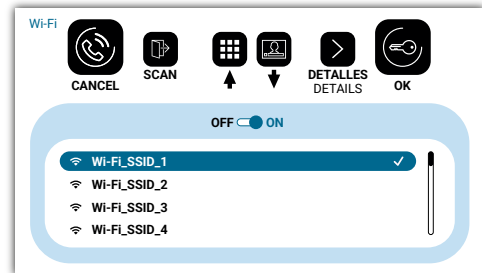
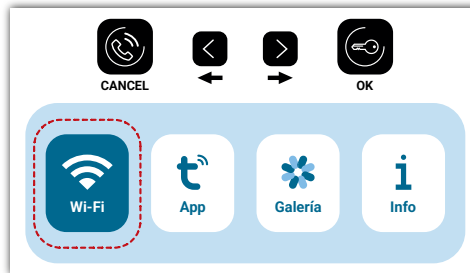

2

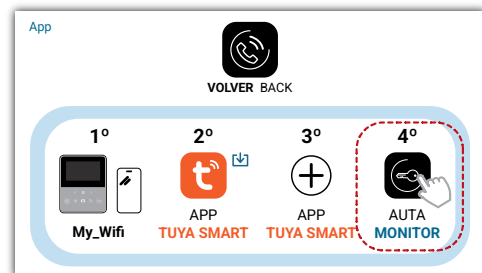
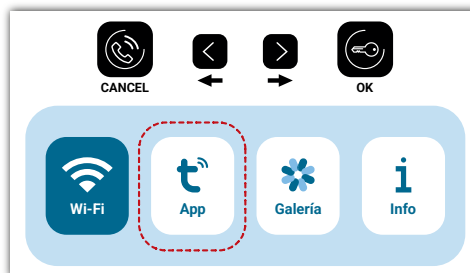

3

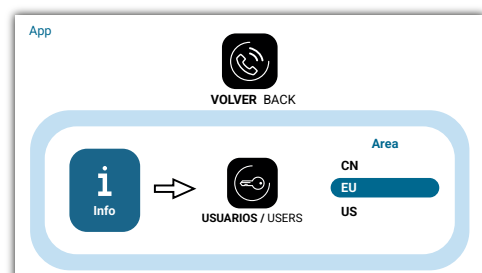
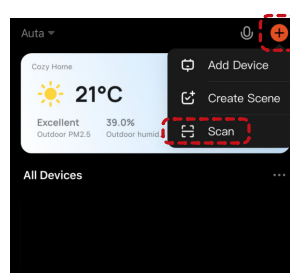
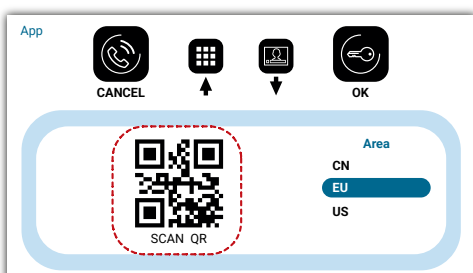

ELEMENTOS UNITS	ALV-1A (716103)
 LLAMADA SIMULTANEA SIMULTANEOUS CALL	3

SECCIONES Y DISTANCIAS RECOMENDADAS RECOMMENDED SECTIONS AND DISTANCES

D1 → Distancia max. total desde placa al monitor
Total max. distance from panel to monitor



Total max. distance from panel to monitor

D2 → Distancia max. desde placa al inyector de alimentación
Max. distance from panel to power injector

Max. distance from panel to power injector

D3 → Distancia max. desde el inyector al monitor
Max. distance from injector to the monitor

Max. distance from injector to the monitor

KVD-1	Distanc. 1 (D1)	Distanc. 2 (D2)	Distanc. 3 (D3)
1 mm ² 	200 m	100 m	100 m
UTP CAT 5_6 100% COBRE (2 pares H y 2 pares H) UTP CAT 5_6 100% COPPER (2 pairs H and 2 pairs H)	180 m	90 m	90 m
1 mm ² 	160 m	80 m	80 m
1.5 mm ² 	80 m	40 m	40 m

- FA → Fuente de alimentación
Power supply unit
- I → Inyector de alimentación
Power injector
- M → Monitor
Monitor

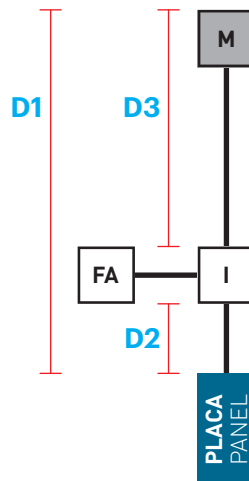

GESTIÓN DE ABREPUERTAS DOOR OPENER MANAGEMENT

