

# neos

## DIGITAL



REF: 743063

**ES** KVD-1 S1 VISUALTECH

**EN** KVD-1 S1 VISUALTECH

**auta**

Bringing people together

## Desmontaje del perfil Profile disassembly

PARA UNA MAYOR COMODIDAD REALIZAR EL PROCESO USANDO UNA SUPERFICIE DE APOYO.

FOR GREATER COMFORT, PERFORM THE PROCESS USING A SUPPORT SURFACE.

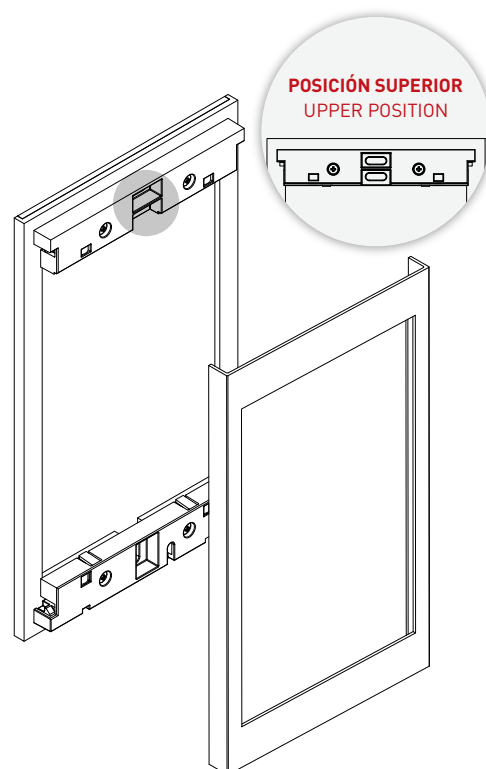
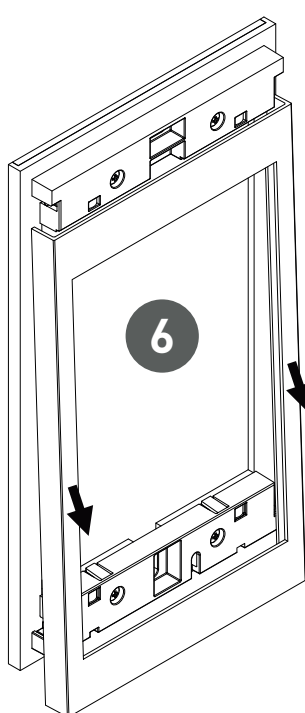
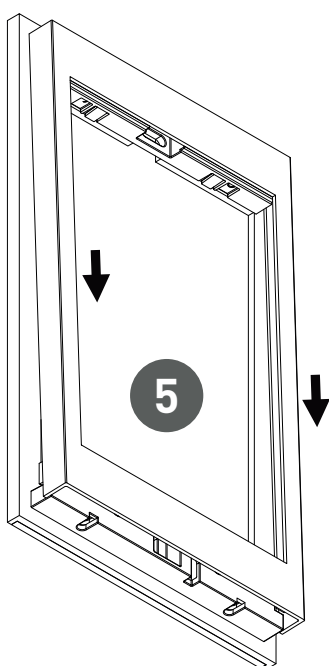
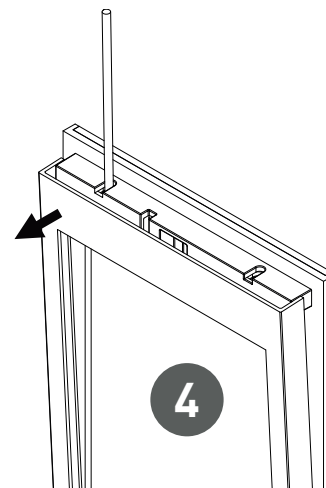
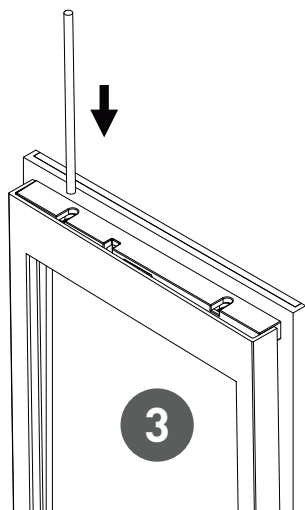
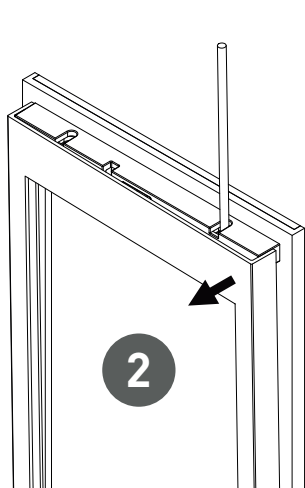
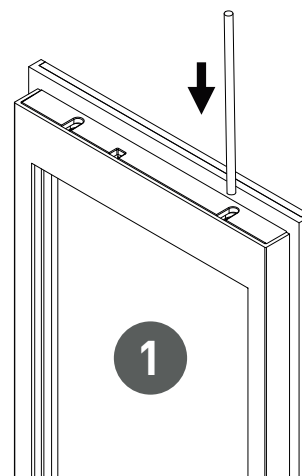
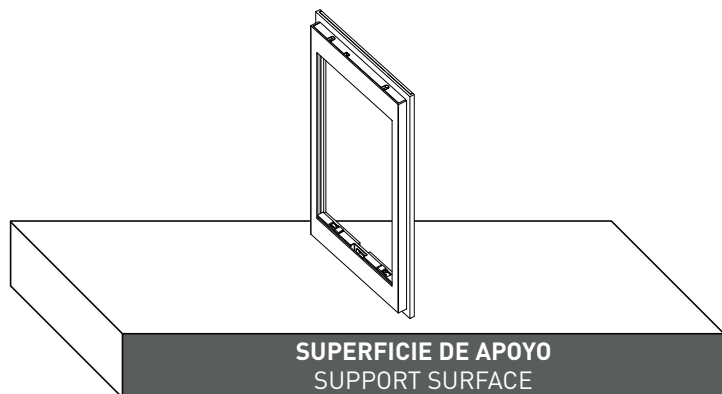

## Elementos en el kit Elements in the kit

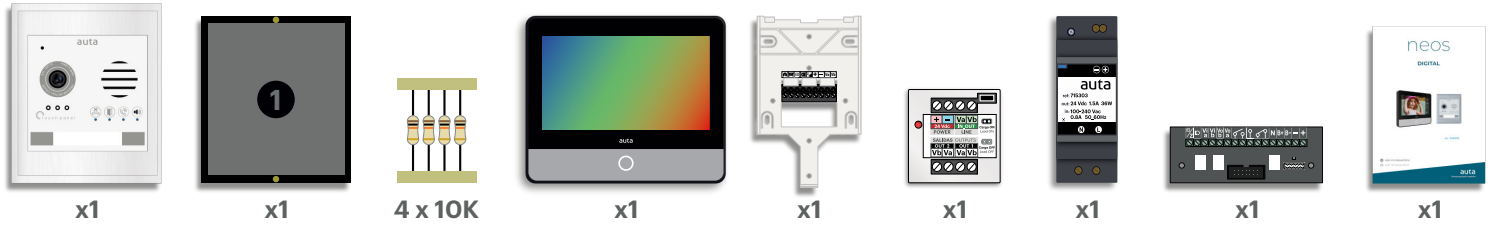

## Colocar información en tarjetero Place information in card holder

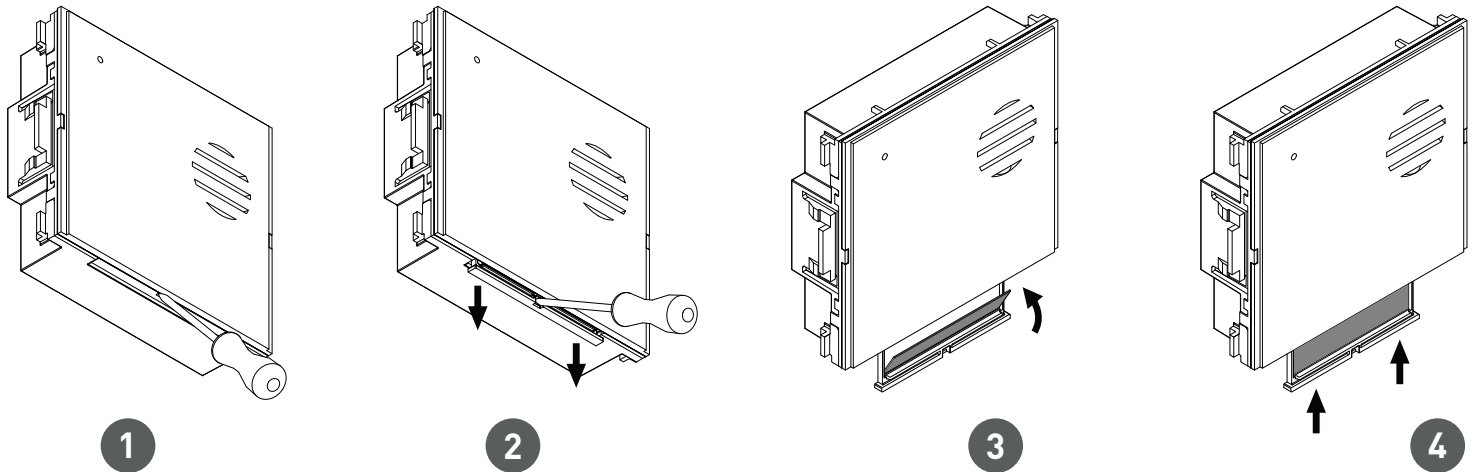

## Descripción Description

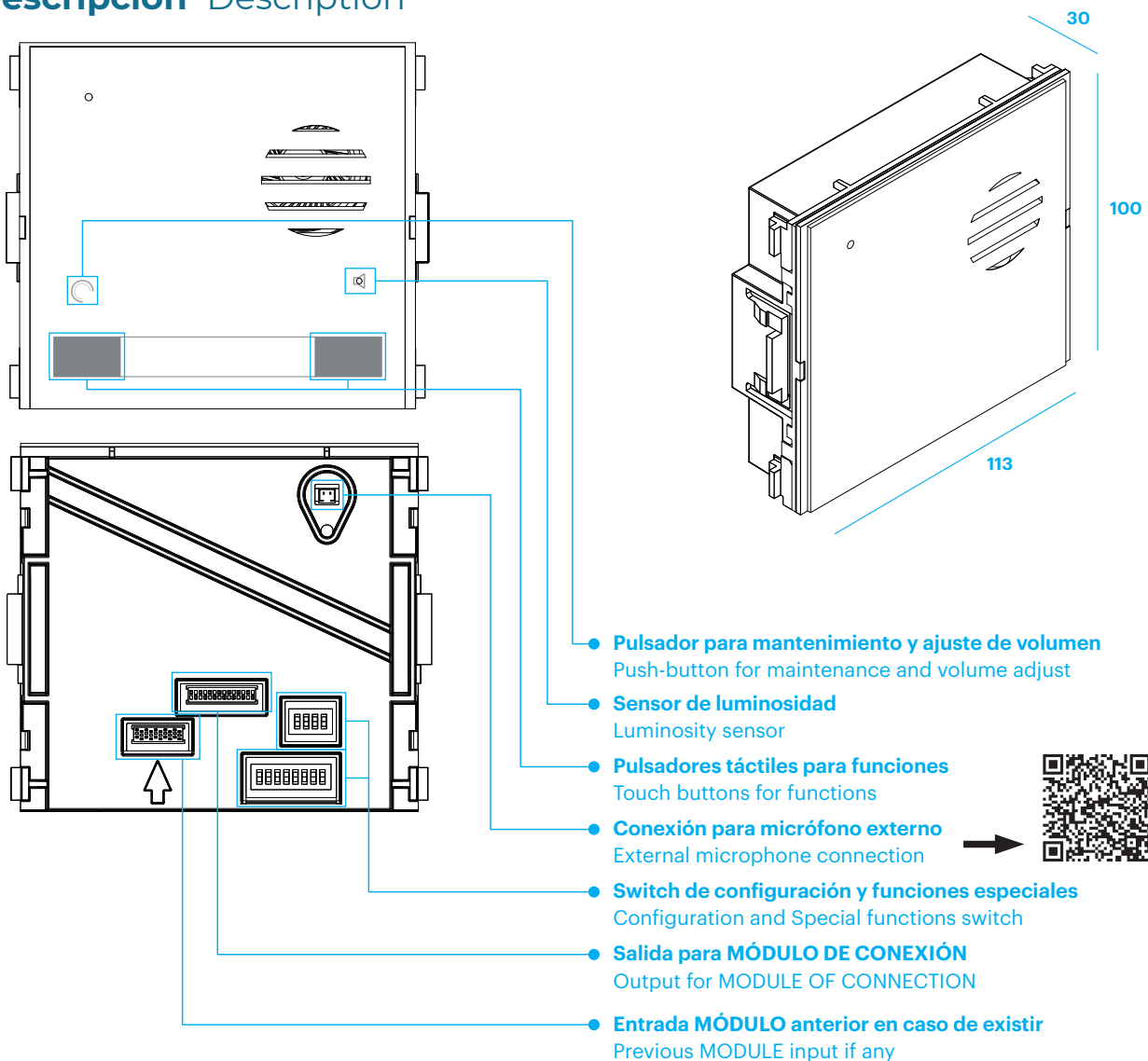

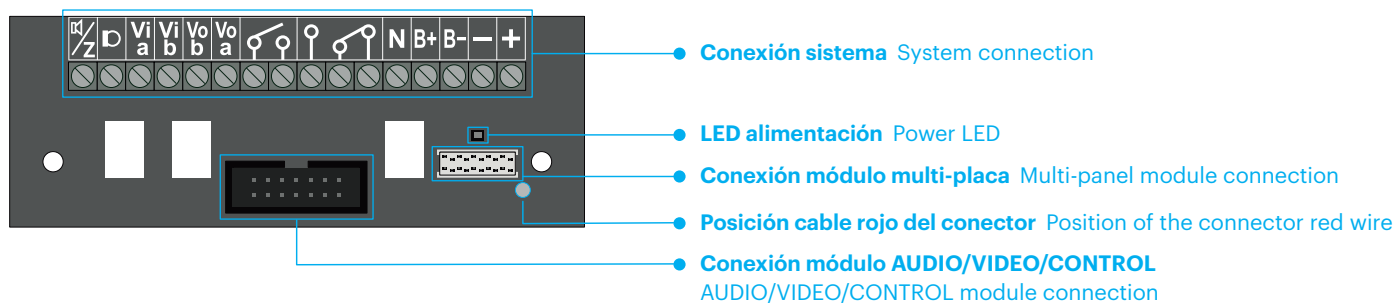

Z	Audio_Datos	Audio_Data
D	Micrófono (solo sistema digital)	Microphone (only digital system)
Vi_a	Video + (entrada)	Video + (in)
Vi_b	Video - (entrada)	Video - (in)
Vo_b	Video - (salida)	Video - (out)
Vo_a	Video + (salida)	Video + (out)
Relé libre de tensión N.A. _1A	Free tension N.O. _1A relay	
Relé libre de tensión N.A. - N.C. _1A	Free tension N.O. - N.C. _1A relay	
N	Salida NEGATIVO PARA MANIOBRAS (solo durante la llamada_conversación)	NEGATIVE out for managements (only during the call_conversation)
B+	Pulsador apertura (terminal 1)	Opening button (terminal 1)
B-	Pulsador apertura (terminal 2)	Opening button (terminal 2)
-	-24 Vcc	-24 Vdc
+	+24 Vcc	+24 Vdc

## Instalación Installation

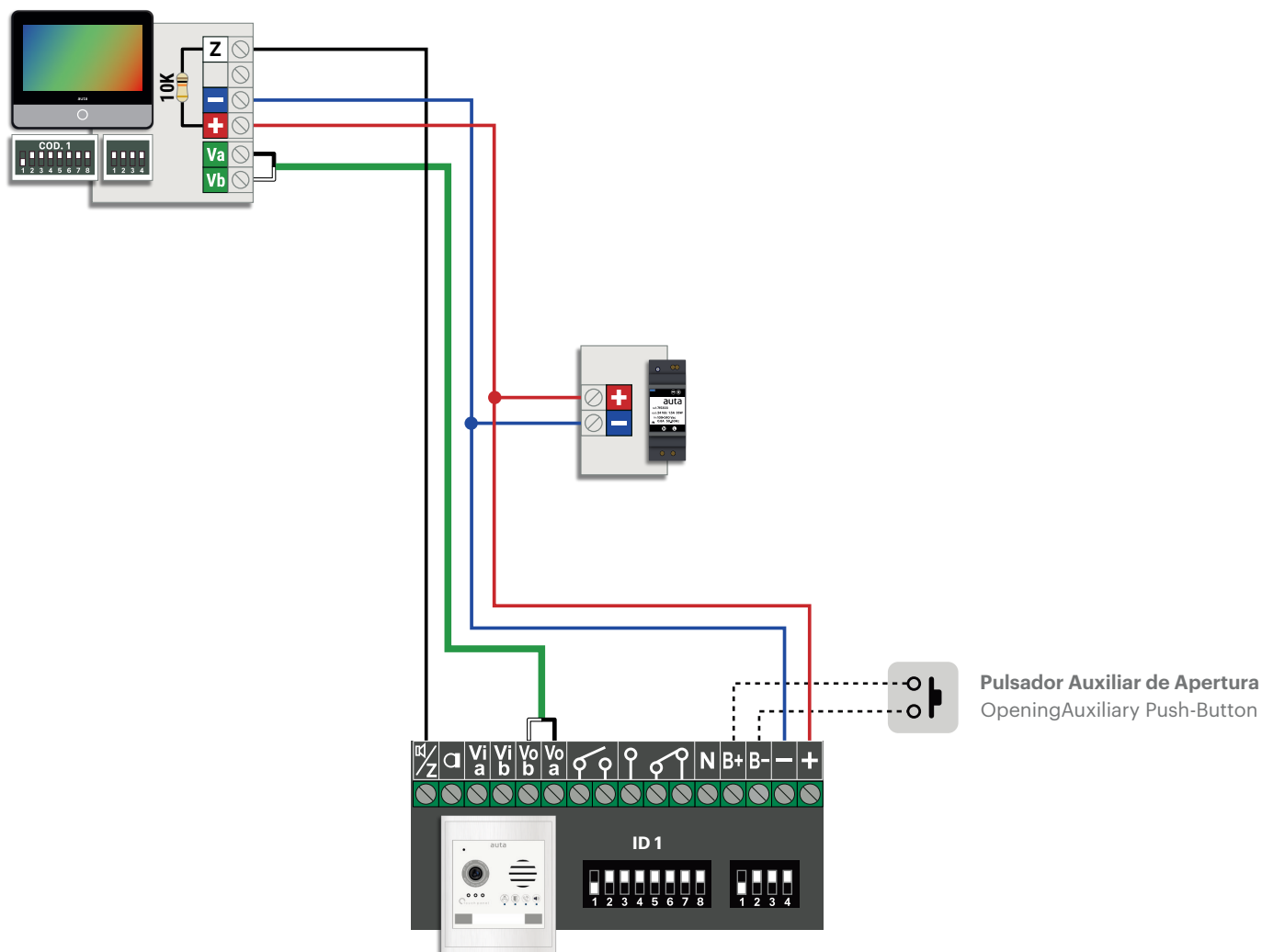

# Configuración Configuration

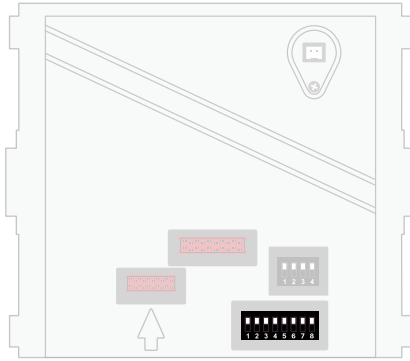

## Configuración de ID de placa Panel ID configuration

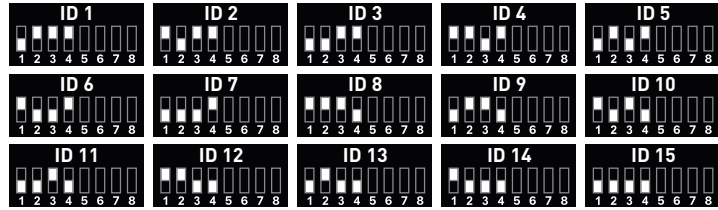

**CÓDIGO RESERVADO**  
la placa emitirá pitidos  
si se utiliza como ID.

RESERVED CODE  
the panel will emit  
beeps if used as ID.



## AUTO-ENCENDIDO a placa SELF-STARTING to panel



## Llamada a CONSERJERÍA Call to CONCIERGE



## SIN USO WITHOUT USE



## Mensaje "PUERTA ABIERTA" "DOOR OPEN" message

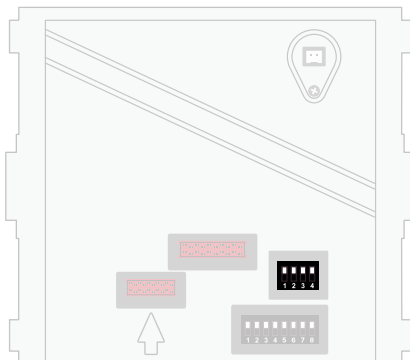

## Selección PRINCIPAL \_ SECUNDARIO MASTER \_ SLAVE selection



**!** Sistema VISUALTECH SIEMPRE OFF  
VISUALTECH system ALWAYS OFF



## Selección de LLAMADA CALL selection

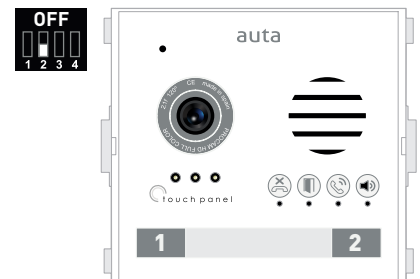
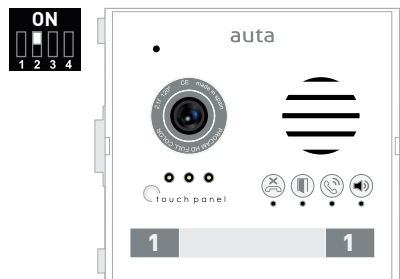

## Selección de MICRÓFONO MICROPHONE selection

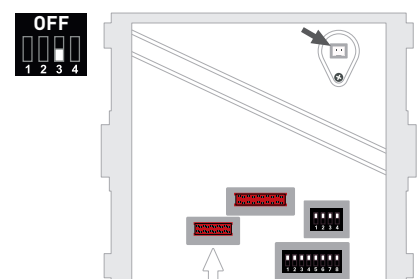
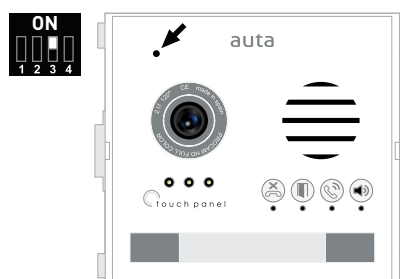

## Funciones especiales Special functions



## MONTAJE MOUNTING



## Ajuste de volumen Volume adjust

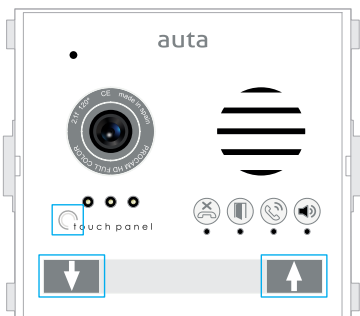

### Entrar en modo ajuste de volumen Enter in volume adjust mode

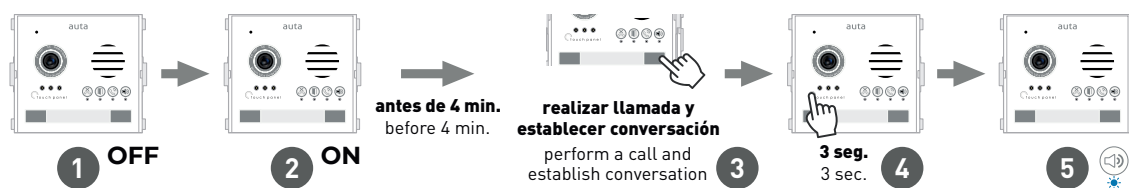

Existen 3 parámetros en los que podemos realizar ajustes de volumen:

1. Volumen de AUDIO en PLACA
2. Volumen de AUDIO en VIVIENDA
3. Volumen de AUDIO en mensaje "PUERTA ABIERTA"

Disponemos de 8 niveles de audio seleccionables, representados por 4 LEDS azules. Cada led indica 2 niveles.

There are 3 parameters in which we can make volume adjustments:

1. AUDIO volume at PANEL
2. AUDIO volume at HOUSING
3. AUDIO volume for "DOOR OPEN" message

We have 8 selectable audio levels, represented by 4 blue LEDs. Each led indicates 2 levels.

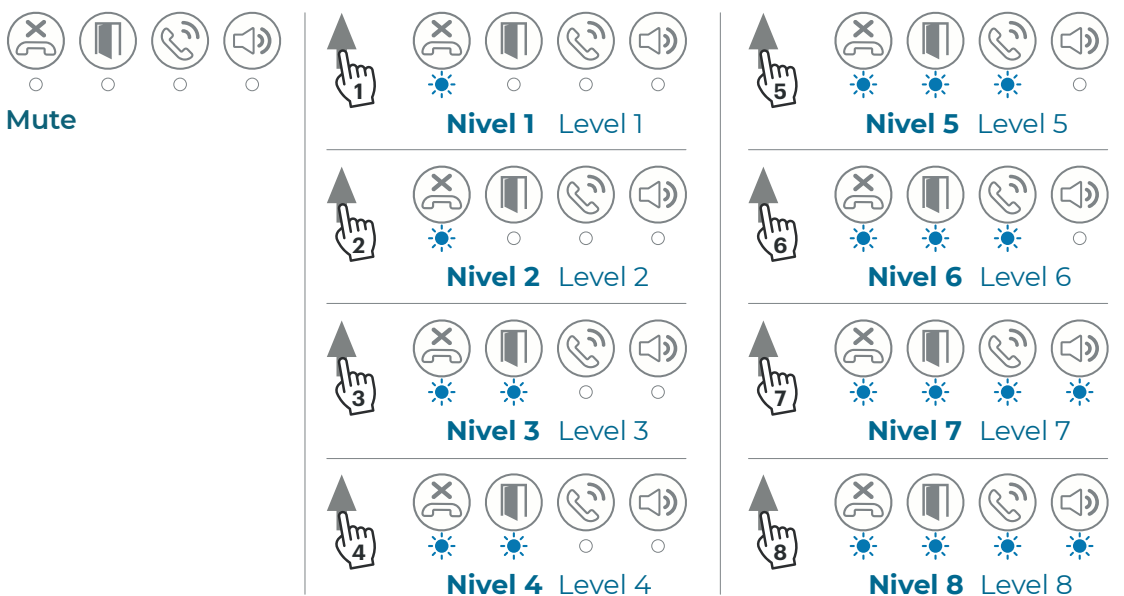

### → Ajuste de balance (solo VISUALTECH) Balance adjust (only VISUALTECH)

**ESTE PROCESO SE REALIZARÁ CON TODOS LOS TERMINALES INSTALADOS Y CONECTADOS. TAMBIÉN COMPROBAREMOS QUE LA RESISTENCIA/S DE FINAL DE LÍNEA ESTÉN COLOCADAS.**

**Si al ajustar el volumen de audio en conversación comprobamos que se produce acoplamiento, deberemos re-ajustar LIGERAMENTE el potenciómetro de balance situado en la parte trasera del módulo Xenia.**

**Cada vez que modifiquemos los niveles de volumen, volveremos a re-ajustar el balance de la instalación.**

THIS PROCESS WILL BE DONE WITH ALL TERMINALS INSTALLED AND CONNECTED. WE WILL ALSO CHECK THAT THE END OF LINE RESISTANCE/S ARE CONNECTED.

If when adjusting the audio volume in conversation we verify that coupling occurs, we will have to SLIGHTLY re-adjust the balance potentiometer located on the back of the Xenia module.

Every time we modify the volume levels we will readjust the balance of the installation.

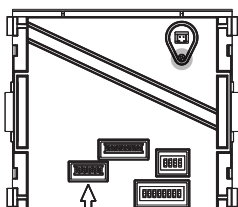

## Montaje Mounting

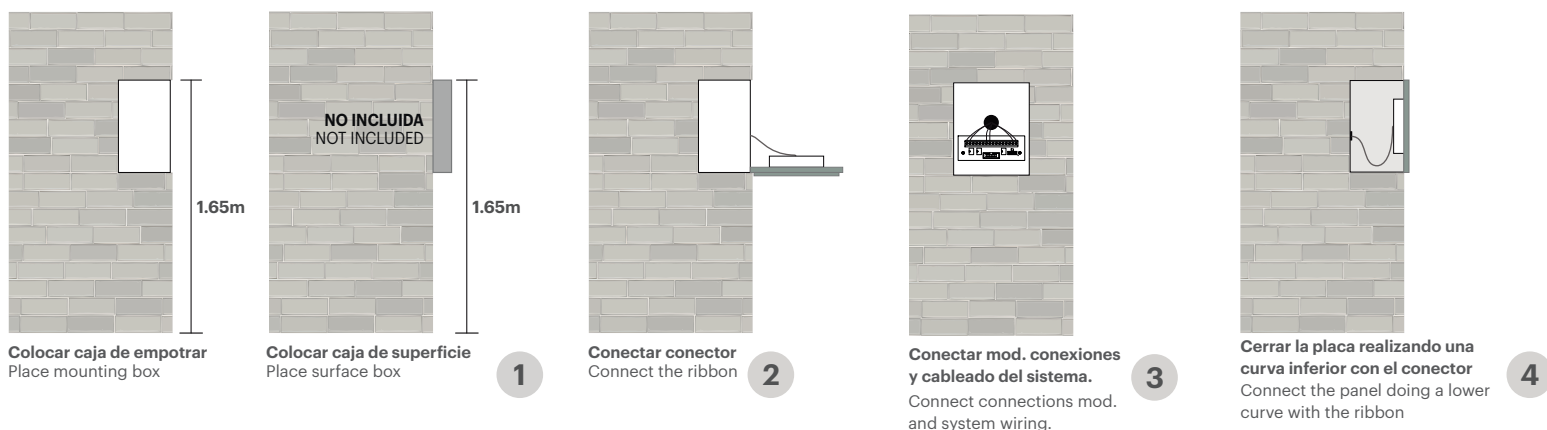

## Montaje del perfil Profile assembly

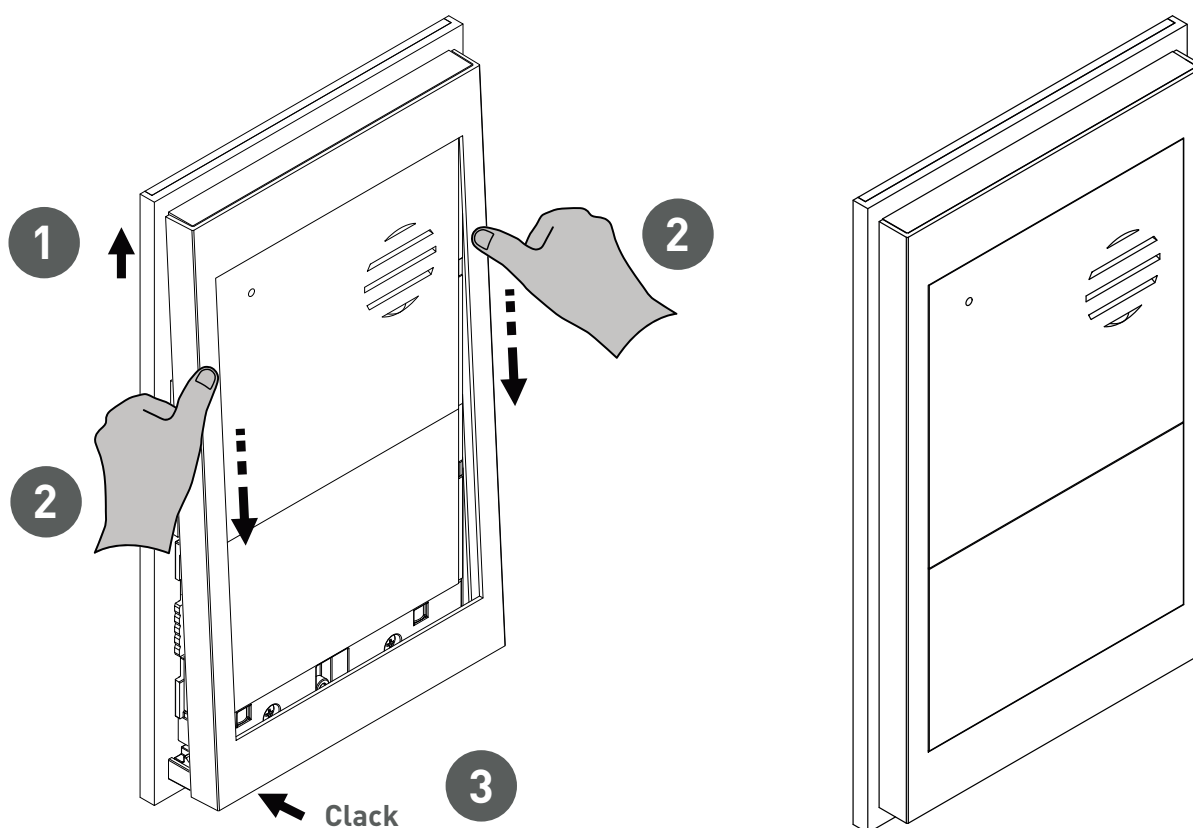

## Modo mantenimiento Maintenance mode

El modo mantenimiento es un modo en el que la placa desactiva todos sus módulos conectados por seguridad, así se pueden realizar procedimientos tales como limpieza o la colocación de información en los tarjeteros de los pulsadores, con total seguridad. El tiempo máximo en el que la placa permanece en modo mantenimiento es de 4 minutos. Pasado este tiempo se deberá re-armar.

The maintenance mode is a mode in which the panel deactivates all its connected modules for safety reasons, so procedures such as cleaning or placing information in the button card holders, can be carried out in complete safety.

The maximum time that the panel remains in maintenance mode is 4 minutes. After this time, it must be re-armed.

### Entrar en modo mantenimiento Enter in maintenance mode

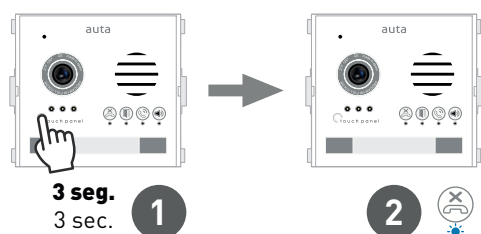

ELEMENTOS UNITS	ALV-1.5A (715303)	ALV-2.5A (715703)
	30	30
	50	100
LLAMADA SIMULTANEA SIMULTANEOUS CALL	3	5

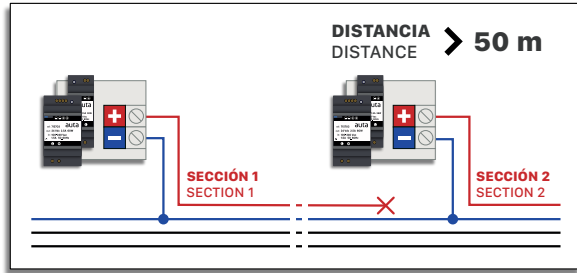

SECCIONES RECOMENDADAS RECOMMENDED SECTIONS



SI EL CABLEADO ESTÁ A MENOS DE 20cm DE LA LÍNEA ELÉCTRICA SE RECOMIENDA QUE SEA APANTALLADO. SE UNIRÁN TODAS LAS PANTALLA ENTRE SI Y SE CONECTARÁN, EN UN PUNTO INTERMEDIO, A TOMA DE TIERRA (VERDE-AMARILLO).

IF THE WIRING IS LESS THAN 20cm FROM THE ELECTRICAL LINE, IS RECOMMENDED IT TO BE SHIELDED. ALL THE SHIELDS WILL BE LINKED TO EACH OTHER AND CONNECTED, AT AN INTERMEDIATE POINT, TO GROUND (GREEN-YELLOW).

UTP_FTP_STP CAT 5_6	AUTA
	+
	-
	Va
	Vb
	Z
100% COBRE	100% COPPER

SECCIONES WIRING SECTIONS	HASTA 100m UP TO 100m
+ - Z Va Vb	0.22mm AWG22
EL CABLEADO NO DEBE PASAR CERCA DE LA LÍNEA ELÉCTRICA WIRING MUST NOT BE RUN CLOSE TO THE ELECTRICAL LINE	

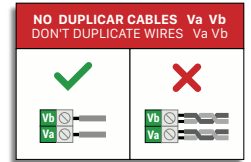

CONFIGURACIÓN DE VIDEO VIDEO CONFIGURATION

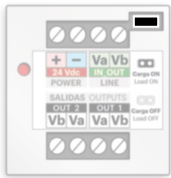

COLOCAR LA CARGA "OFF" EN TODOS LOS DISTRIBUIDORES DE LA MISMA LINEA EXCEPTO EN EL ÚLTIMO.

SET THE LOAD "OFF" AT ALL VIDEO DISTRIBUTORS IN THE SAME LINE EXCEPT AT LAST ONE.

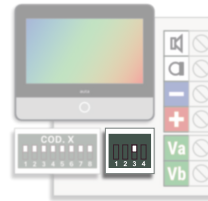

EN SISTEMAS CON DISTRIBUCION EN CASCADA COLOCAR EL SWITCH 3 ABAJO (OFF) EN TODOS LOS MONITORES DE LA MISMA LINEA EXCEPTO EN EL ÚLTIMO.

AT SYSTEMS WITH SERIAL DISTRIBUTION SET THE SWITCH 3 DOWN (OFF) AT ALL MONITORS IN THE SAME LINE EXCEPT AT THE LAST ONE.

GESTIÓN DE ABREPUERTAS DOOR OPENER MANAGEMENT

